

CPS-HC-30R-TS

Product Description

This 30 cu. ft. touchscreen laboratory refrigerator redefines precision and user experience for critical sample storage, backed by microprocessor temperature control. These units utilize natural hydrocarbon refrigerants for EPA SNAP compliance and eco-friendly cooling. This model offers exceptional temperature uniformity and extensive data logging and charting capabilities for auditing and compliance. Access a 24-hour temperature chart and data logging capabilities through an intuitive touchscreen interface. Experience an extensive array of customizable audible and visual alarms, including high/low-temperature, sensor error, power failure, door ajar, and low battery alerts, all supported by a battery backup and remote alarm contacts. This unit is constructed with durable white powder-coated steel and protected by a secure keyed door lock. Adjustable interior shelving allows for versatile organization. The CPS-HC-30R-TS refrigerator provides a reliable, energy-efficient and user-centric solution for any laboratory needing precise temperature control and data logging capabilities.

Images



Certifications



General Description and Application

Storage capacity (cu. ft)	30 Cu. Ft.
Door	One solid swing, right hinged; stainless steel door handle; magnetic door gasket
Shelves	Five adjustable
Mounting and Installation	Caster platform
Airflow Management	Forced draft circulation
External probe access	3/4" probe access port on rear wall
Insulation	EPA compliant high density urethane foam
Exterior materials	Powder coated steel
Access control	Keyed door lock
General warranty	Two (2) year parts and labor warranty
Compressor warranty	Five (5) year compressor parts warranty
Product Weight (lbs)	350
Shipping Weight (lbs)	380
Rated Amperage	3.1 Amps
Power Plug/Power Cord	NEMA 5-15P plug, 6 ft long cord
Facility Electrical Requirement	110 - 120V AC, 15A breaker, NEMA 5-15 receptacle
Agency Listing and Certification	UL listed per UL 60335-1 and UL 60335-2-89 standards; c UL listed per CSA C22.2 No. 120 standard

Performance

Uniformity (Cabinet air)	+/- 1.6°C
Stability (Cabinet air)	+/- 1.0°C
Maximum temperature variation (Cabinet air)	3.6 °C Total
Energy Consumption (KWh/day)	< 1.7 KWh/day
Average Heat Rejection (BTU/hr)	520 BTU/hr
Pull down time to nominal operating temp	<35 min (empty)

Performance data based on an empty chamber at steady state using buffered temperature probes per Energy Star test method for Laboratory Grade Refrigerators and Freezers. Product loading, door openings, and ambient conditions will affect performance.

Refrigeration System	
Compressor	Hermetic, variable speed
Refrigerant	EPA SNAP compliant R600a Isobutane
Condenser	Static - exterior walls of cabinet
Evaporator	Fin and tube design, high efficiency fan
Defrost	Off-cycle defrost, no heat added

Controller, Configuration, Alarms and Monitoring	
Controller technology	Microprocessor temperature controller with variable frequency compressor control
Battery Backup	Temperature display and alarm only (no active cooling)
Display technology	Touch screen digital temperature display with user friendly interface, real-time operational display clock, active temperature scale bar display, resettable 1-point min/max history, digital 24- hour temperature chart, and temperature data logging
Temperature Setpoint Range Notes	Minimum temperature limited to avoid freezing
Adjustable Temperature Range	2°C to 10°C
External alarm connection	Remote alarm contacts
Alarms	Adjustable alarm volume, Audible and visual high and low temperature alarms, sensor error alarm, power failure alarm, door ajar alarm, low battery alarm, alarm validation (audible, visual, and remote alarm), alarm mute with ring back, and customizable alarm time delay settings
Display Probe	Product simulator bottle with glass bead media
Disclaimers	Refrigerator requires a minimum 4" of clearance around back and sides of the unit for proper ventilation (more if next to heat rejecting equipment) - improper installation will void the warranty and will lead to temperature maintenance issues, overheating and possible failure

Dimensions

	Width (in.)	Depth (in.)	Height (in.)	Door Swing (in.)	Total open Depth (in.)
Exterior	35.75"	35.5"	83"	30.5"	66"
Interior	32"	22.5"	65"		

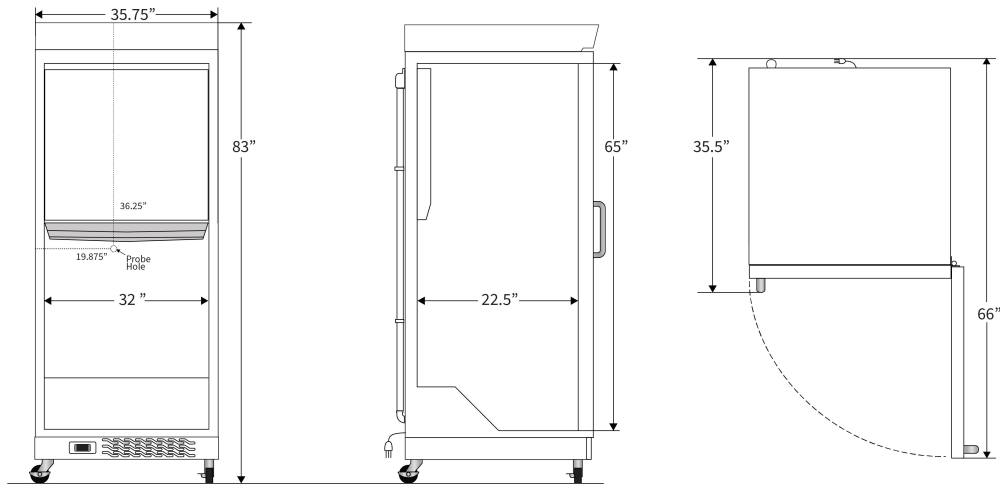

Contact		
Customer Service	800-648-4041 Option 3	customerservice@horizonscientific.com
Technical Service	800-648-4041 Option 5, Parts Option 4	technicalservice@horizonscientific.com