

Washer Disinfecter

Cart & Utensil Washer Series

Heavy duty, high performance, rotating spray, cart & utensil washer.



Model	Standard Chamber Size	Standard Unit Size	Pump
SW6100	41" W x 84" H x 80" D	55.5 W x 91" H x 84" D	7.5 HP
SW6400	48" W x 88" H x 90" D	62.75" W x 95" H x 96" D	10 HP
SW6400L	48" W x 88" H x 128" D	62.75" W x 95" H x 132" D	15 HP
SW6400WL	68.5" W x 88" H x 128" D	83.25" W x 95" H x 132" D	20 HP

All heights measured from finished floor level.

Features

- Heavy-duty Hinge Door
- Modular Construction
- Knock-down Shipment
- Rotating Spray Delivery System
- Personnel Safety Features
- PLC Control System with Full Color HMI Touch Screen
- 10 Configurable Cycles
- Automatic Self-cleaning Screen
- Temperature Guarantee
- Insulated Construction
- Incoming Utility Gauges
- Interior Illumination
- SS Recirculation Piping and Components
- Non-proprietary Parts

Accessories

- Internal Drop in Tilt Ramps
- Exterior Load Ramps (for floor mounted models)
- Multi-tier Utensil Wash Cart
- Flat Deck Washing System
- Bottle Washing Spindle Cart

Options

- Shallow Base Unit (6")
- Pit or Floor Mounted
- Pass-thru Unit
- Right or Left Hand Services
- House Hot Water Heat Exchanger
- Integral Data Collection System
- Drain Discharge Cooling
- Automatic Damper
- SS Exhaust Fan
- Low Steam Pressure Package
- Pass-thru Door Interlock System
- Air Compressor
- Printer
- Seismic Tie Down
- Detergent Dispensing Systems
- pH Neutralization System
- Split Base for Special Entry
- Utility Enclosure Panels
- Inclined Floor Grating Barrier
- Wall Flange(s)
- Devapourmatic System

- Chemical Level Monitoring System
- Direct quick connect cart washing spray option
- Electric Heating In Place of Steam

Construction

Heavy-duty stainless steel doors with port view glass windows.

Recirculated water is heated by a stainless steel steam coil to achieve guaranteed treatment temperatures.

Stainless steel treatment pumps.

Utilities

	All Models	SW6100	SW6400	SW6400L	SW6400WL
Electrical (E)	3-60-208/480V	14HP	19HP	21HP	24HP
Hot Water (HW)	1½" NPT, 35 PSI, 50 GPM @ 140° F ± 5° F	45 Gallon Sump	62 Gallon Sump	75 Gallon Sump	85 Gallon Sump
Cold Water (CW)	1½" NPT, 35 PSI, 50 GPM @ 60° F ± 5° F				
Steam (S)	2" NPT, 45-80 PSI, Dynamic ± 5 PSI	800-1200 #/Hr	800-1200 #/Hr	1200-1800 #/Hr	1200-1800 #/Hr
Condensate (C)	1" NPT				
Air (A)	¼" NPT, 80-100 PSI, 4-6 CFM Flow Rate				
Drain (D)	12" x 12" x 8" Floor Sink with 4" Floor Drain (<i>minimum</i>), 350 GPM Flow Rate				
Vent (V)	12" ID Duct, 750 CFM, Saturated Vapor @ 190° F				

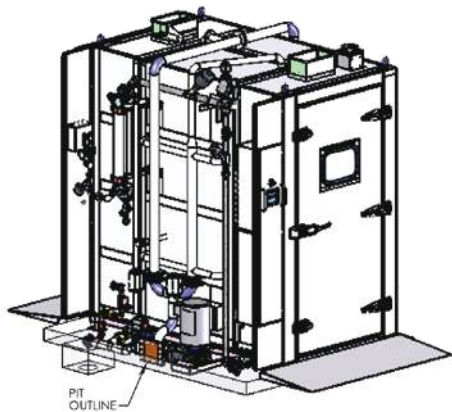

Top View

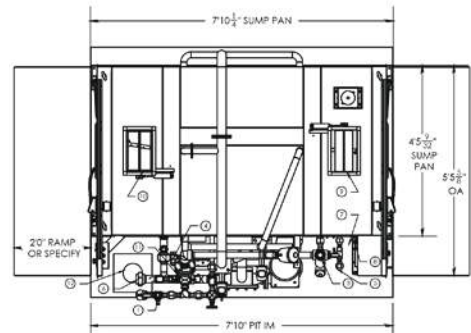

Front View

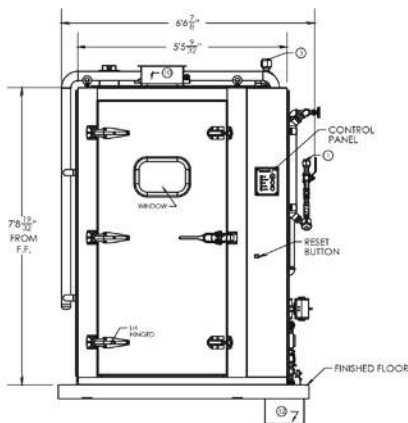

Side View

