



Cage & Rack Washer

Model 455LX

Pit or floor mounted washer with oscillating spray cleaning for animal care items.

Model	Standard Chamber Size <i>W x H x D</i>	Standard Unit Size <i>W x H x D</i>	Opt. Door Widths	Opt. Door Heights	Opt. Chamber Lengths
455LX	Dual 46" x 85" x 141"	147" x 104" x 93"-196"	36", 48", 54"	88", 93", 96"	All 85" - 188"+

Features

- Pit mounting
- LYNX IDEC Controls System
- (2) 1/3 size viewing windows
- Dual load chambers
- Heavy-duty hinge doors
- Modular Construction
- Knock-down Shipment
- Oscillating Spray Delivery System
- Recirculated water is heated by a stainless steel steam coil to achieve guaranteed treatment temperatures.
- 10 HP treatment pump with a direct read pump pressure gauge.
- Personnel Safety Features
- Full Color HMI Touch Screen
- 12 Configurable Cycles
- Neutralization System
- Automatic Self-cleaning Screen
- Temperature Guarantee
- Insulated Construction
- Incoming Utility Gauges
- Interior Illumination
- SS Recirculation Piping and Components
- Non-proprietary Parts

Construction

- Cabinet Construction - 14 ga 304 SS

Options

- Pit or Floor Mounted
- Pass-thru Unit
- Right or Left Hand Services
- LYNX OPTI-Wash™ Water Saving System
- Re-usable Throwing Alkaline and/or Acid Tank Heated Rinse Tank
- House Hot Water Heat
- Exchanger
- Electric Heat System
- Integral Data Collection System
- LYNX Smart-Cool™ System
- Drain Discharge Cooling -Injected/Tank
- Automatic Damper
- SS Exhaust Fan
- Low Steam Pressure Package
- Pass-thru Door Interlock System
- Air Compressor
- Printer
- Seismic Tie Down
- Detergent Dispensing Systems
- pH Neutralization System
- Feeder Bottle Washing System
- Integrated Pan Wash System
- Automatic Water Rack
- Flush System
- Split base for special entry
- Port-view door window

Accessories

- Floor Ramps
- Modular Walls
- Bottle Wash Cart
- Universal cage wash cart

Utilities

Electrical (E)	3-60-208/480V, 22-32HP
Hot Water (HW)	1½" NPT, 35 PSI, 50 GPM @ 140° F ± 5° F (40 gallon sump capacity)
Cold Water (CW)*	1½" NPT, 35 PSI, 100 GPM @ 50° F ± 5° F
Steam (S)	2" NPT, 45-80 PSI, Dynamic ± 5 PSI, 1000-1200 #/Hr Flow Rate
Condensate (C)	2" NPT
Air (A)	½" NPT, 80-100 PSI, 4-6 CFM Flow Rate
Drain (D)	(2) 12" x 12" Floor Sink with (2) 4" Floor Drain (<i>minimum</i>), 180 GPM Flow Rate
Vent (V)	12" ID Duct, 750 CFM, Saturated Vapor @ 190° F

*CW - Required if drain discharge cool-down package ordered

Drawings

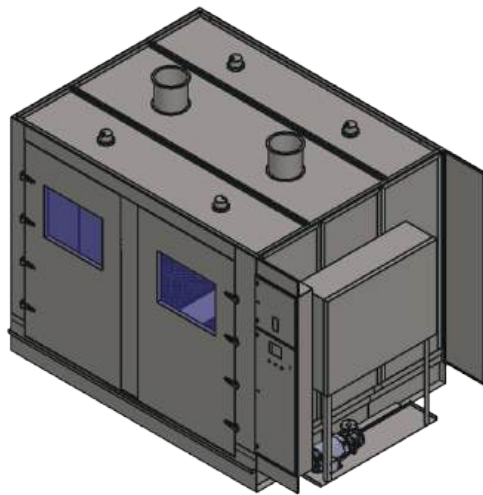

Top View

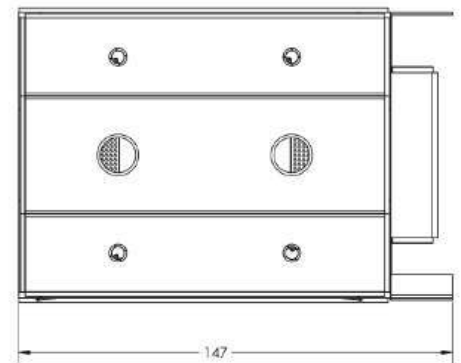

Front View

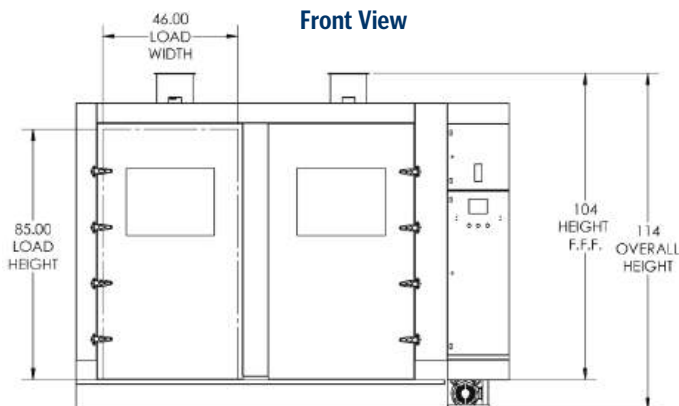

Side View

