



# Cage & Rack Washer

## Model 450RS

Heavy duty, large-capacity hydro-spray washer that is easy to use, and has the highest cleanability rating.

| Model | Standard Chamber Size<br>W x H x D | Standard Unit Size<br>W x H x D | Opt. Door Widths | Opt. Door Heights | Opt. Chamber Lengths         |
|-------|------------------------------------|---------------------------------|------------------|-------------------|------------------------------|
| 450RS | 68" x 88" x 128"                   | 83.25" x 95" x 132"             | 62", 74", 84"    | 90", 93", 96"     | 109", 140", 150", 160", 165" |

*Washers can be customized to any size to meet your application requirements.*

### Features

- Heavy-duty hinge door
- Heavy-duty stainless steel doors with port view glass windows.
- Modular construction
- Knock-down shipment
- Rotating spray delivery system
- Personnel safety features
- Allen Bradley Controls MicroLogix PLC System
- Full Color HMI
- Re-usable/throwaway alkaline tank
- House Hot Water Heat Exchanger
- Recirculated water is heated by a stainless steel steam coil to achieve guaranteed treatment temperatures.
- Stainless steel 20 HP treatment pump with a direct read pump pressure gauge.
- 10 configurable cycles
- Automatic self-cleaning screen
- Temperature guarantee
- Insulated construction
- Incoming utility gauges
- Interior illumination
- SS recirculation piping and components
- Non-proprietary parts

### Options

- Shallow Base Unit (6")
- Pit or Floor Mounted
- Pass-thru Unit
- Right or Left Hand Services
- Integral Data Collection System
- Drain Discharge Cooling
- Automatic Damper
- SS Exhaust Fan
- Low Steam Pressure Package
- Pass-thru Door Interlock System
- Air Compressor
- Printer
- Seismic Tie Down
- Detergent Dispensing Systems
- pH Neutralization System
- Feeder Bottle Washing System
- Automatic Water Rack Flush System
- Split Base for Special Entry
- Utility Enclosure Panels
- Inclined Floor Grating
- Barrier Wall Flange(s)

### Accessories

- Floor Ramps
- Bottle Wash Cart
- Universal Cage Wash Cart
- High Capacity Cage Wash System

### Construction

- Cabinet Construction - 16 ga 304 SS

## Utilities

|                         |  |
|-------------------------|--|
| <b>Electrical (E)</b>   | 3-60-208/480/600V, 23HP  |
| <b>Hot Water (HW)</b>   | 1" NPT, 35 PSI, 25 GPM @ 140° F ± 5° F (125 gallon sump capacity)              |
| <b>Cold Water (CW)*</b> | 1" NPT, 35 PSI, 25 GPM @ 50° F ± 5° F  |
| <b>Steam (S)</b>        | 1½" NPT, 40-60 PSI, Dynamic ± 5 PSI, 1000 #/Hr Flow Rate                       |
| <b>Condensate (C)</b>   | 1" NPT + ¾" NPT  |
| <b>Air (A)</b>          | ¼" NPT, 80-100 PSI, 1-2 CFM Flow Rate  |
| <b>Drain (D)</b>        | 12" x 12" Floor Sink with 4" Floor Drain ( <i>minimum</i> ), 530 GPM Flow Rate |
| <b>Vent (V)</b>         | 8" x 22" Duct, Saturated Vapor @ 190° F, 1 DC (1200 CFM) + 1 IDC (500 CFM)     |

\*CW - Required if drain discharge cool-down package ordered

## Drawings

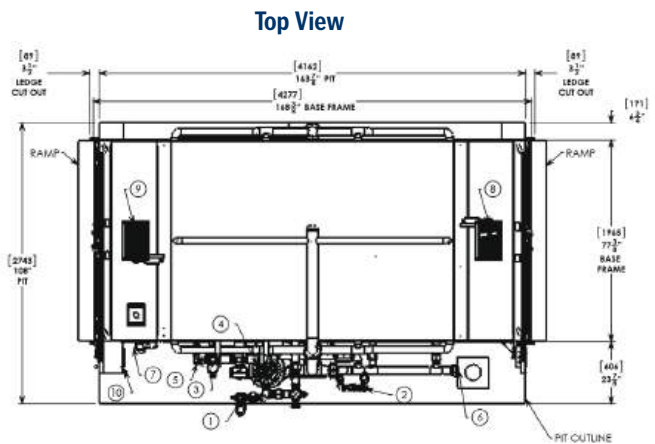
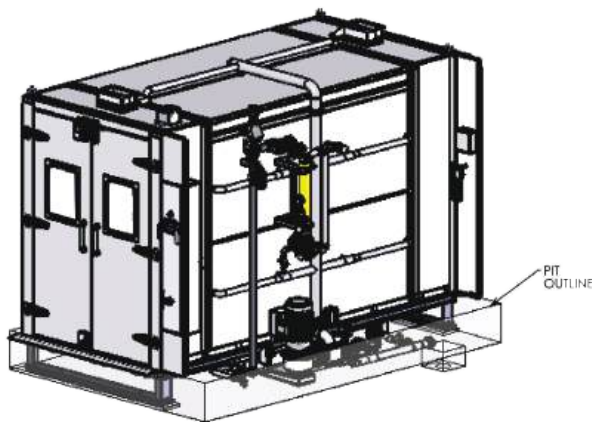

**Side View**

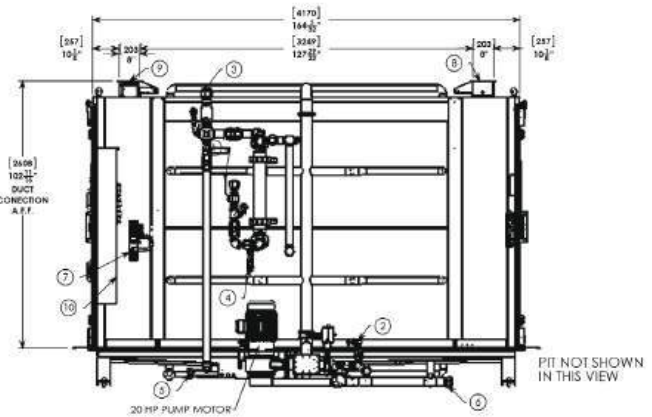

**Front View**

