



Cage & Rack Washer

Model 430RS

A heavy duty, large-capacity hydro-spray washer that is easy to use, requires minimal maintenance, and has the highest cleanability.

Model	Standard Chamber Size <i>W x H x D</i>	Standard Unit Size <i>W x H x D</i>	Opt. Door Widths	Opt. Door Heights	Opt. Chamber Lengths
430RS	48" x 88" x 188"	62.75" x 95" x 192"	42", 46"	74", 82"	154", 164", 170"

Washers are customizable.

Features

- Heavy-duty Hinge Door
- heavy-duty stainless steel door with port view glass window.
- Modular construction
- Knock-down shipment
- Stainless steel, 20 HP treatment pump with a direct read pump pressure gauge.
- Rotating spray delivery system
- Personnel safety features
- Allen Bradley Controls MicroLogix PLC System
- Full Color HMI Touch Screen
- 10 Configurable Cycles
- Automatic Self-cleaning Screen
- Temperature Guarantee
- Insulated Construction
- Incoming Utility Gauges
- Interior Illumination
- SS Recirculation Piping and Components
- Non-proprietary Parts

Options

- Shallow Base Unit (6")
- Pit or Floor Mounted
- Pass-thru Unit
- Right or Left Hand Services
- Re-usable Throwing Alkaline Tank
- House Hot Water Heat Exchanger
- Integral Data Collection System
- Drain Discharge Cooling
- Automatic Damper
- SS Exhaust Fan
- Low Steam Pressure Package
- Pass-thru Door Interlock System
- Air Compressor
- Printer
- Seismic Tie Down
- Detergent Dispensing Systems
- pH Neutralization System
- Feeder Bottle Washing System
- Automatic Water Rack Flush System
- Split Base for Special Entry
- Utility Enclosure Panels
- Inclined Floor Grating
- Barrier Wall Flange(s)

Construction

- Cabinet Construction - 16 ga 304 SS

Accessories

- Floor Ramps
- Bottle Wash Cart
- Universal Cage Wash Cart
- High Capacity Cage Wash System

Utilities

Electrical (E)	3-60-208/480/600V, 23HP
Hot Water (HW)	1" NPT, 35 PSI, 25 GPM @ 140° F ± 5° F (95 gallon sump capacity)
Cold Water (CW)*	1" NPT, 35 PSI, 25 GPM @ 50° F ± 5° F
Steam (S)	2" NPT, 40-60 PSI, Dynamic ± 5 PSI, 900 #/Hr Flow Rate
Condensate (C)	1" NPT + 3/4" NPT
Air (A)	1/4" NPT, 80-100 PSI, 1-2 CFM Flow Rate
Drain (D)	12" x 12" Floor Sink with 4" Floor Drain (<i>minimum</i>), 550 GPM Flow Rate
Vent (V)	8" x 22" Duct, Saturated Vapor @ 190° F, 1 DC (1200 CFM) + 1 IDC (500 CFM)

*CW - Required if drain discharge cool-down package ordered

Drawings

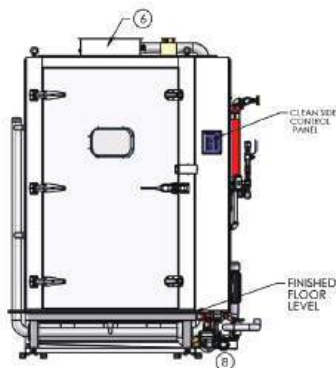
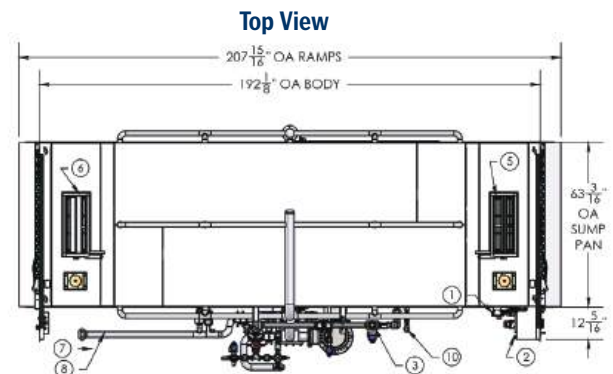
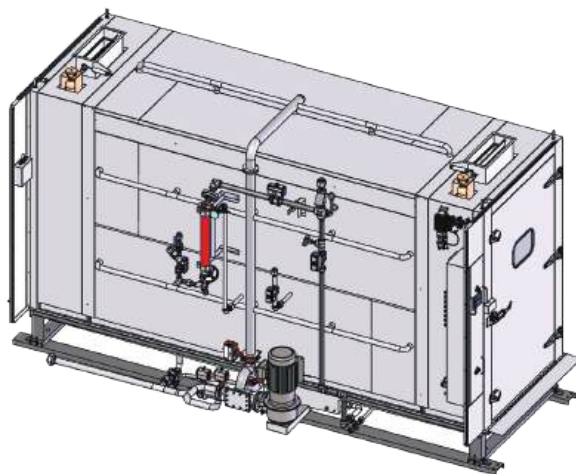

Side View

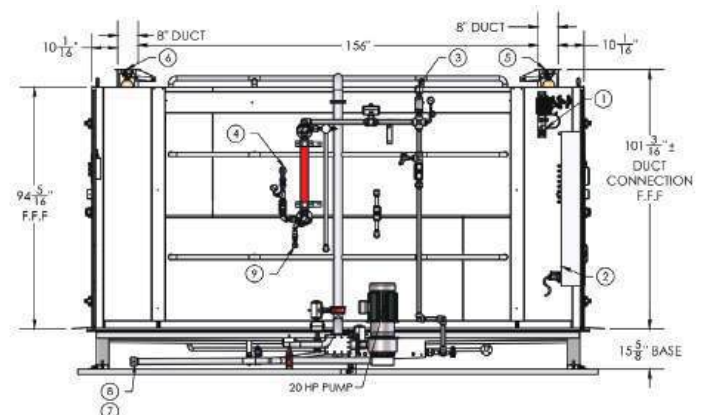

Front View