

Spire Integrated Solutions manufactures the LYNX brand of Vivarium Washing equipment.



Cage & Rack Washer

Model 430LX

Customizable, hydro-spray washers designed for ease of use, minimal maintenance, and highest cleanability.

Model	Standard Chamber Size <i>W x H x D</i>	Standard Unit Size <i>W x H x D</i>	Opt. Door Widths	Opt. Door Heights	Opt. Chamber Lengths
430LX	46" x 85" x 188"	89" x 104" x 196"	36", 48", 54"	88", 93", 96"	152", 164", 170", 176", 188"+

Features

- Pit mounting
- Heavy-duty Hinge Door
- Modular Construction
- Knock-down Shipment
- Oscillating Spray Delivery System
- Personnel Safety Features
- PLC Control System with Full Color HMI Touch Screen
- 12 Configurable Cycles
- Neutralization System
- Automatic Self-cleaning Screen
- Temperature Guarantee
- Insulated Construction
- Incoming Utility Gauges
- Interior Illumination
- SS Recirculation Piping and Components
- Recirculated water is heated by a stainless steel steam coil to achieve guaranteed treatment temperatures.
- (2) stainless steel 10 HP treatment pumps with direct read pump pressure gauges.

Options

- Floor Mounting
- Pass-thru Unit
- Right or Left Hand Services
- LYNX OPTI-Wash™ Water Saving System
- Re-usable Throwing Alkaline and/or Acid Tank
- Heated Rinse Tank
- House Hot Water Heat Exchanger
- Electric Heat System
- Integral Data Collection System
- LYNX Smart-Cool™ System
- Drain Discharge Cooling -Injected/Tank
- Automatic Damper
- SS Exhaust Fan
- Low Steam Pressure Package
- Pass-thru Door Interlock System
- Air Compressor
- Printer
- Seismic Tie Down
- Detergent Dispensing Systems
- pH Neutralization System
- Feeder Bottle Washing System
- Integrated Pan Wash System
- Automatic Water Rack Flush System
- Split Base for Special Entry
- Port-view Door Window
- 36"-54" Door Widths
- Active Door Seal
- Utility Enclosure Panels
- Inclined Floor Grating
- Automatic Inclined Floor Grating
- Steam Heated Dryer System
- Barrier Wall Flange(s)

Accessories

- Floor Ramps
- Modular Walls
- Bottle Wash Cart
- Universal Cage Wash Cart

Construction

- Cabinet Construction - 14 ga 304 SS
- 46" wide standard door

Utilities

Electrical (E)	3-60-208/480V, 24HP
Hot Water (HW)	1½" NPT, 35 PSI, 50 GPM @ 140° F ± 5° F (75 gallon sump capacity)
Cold Water (CW)*	1½" NPT, 35 PSI, 100 GPM @ 50° F ± 5° F
Steam (S)	2" NPT, 45-80 PSI, Dynamic ± 5 PSI, 1000-1200 #/Hr Flow Rate
Condensate (C)	2" NPT
Air (A)	½" NPT, 80-100 PSI, 4-6 CFM Flow Rate
Drain (D)	(2) 12" x 12" Floor Sink with (2) 4" Floor Drain (<i>minimum</i>), 180 GPM Flow Rate
Vent (V)	12" ID Duct, 750 CFM, Saturated Vapor @ 190° F

*CW - Required if drain discharge cool-down package ordered

Drawings

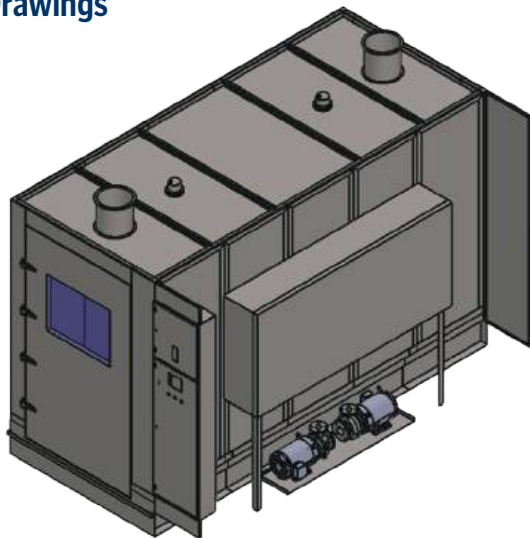

Top View

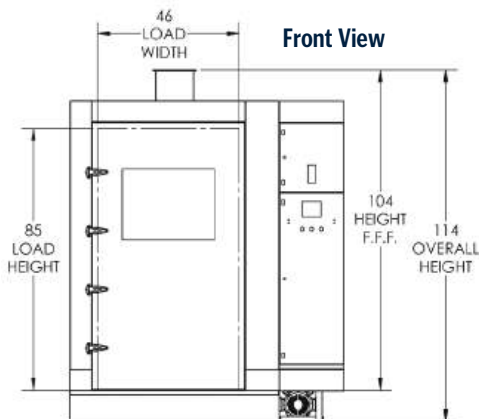
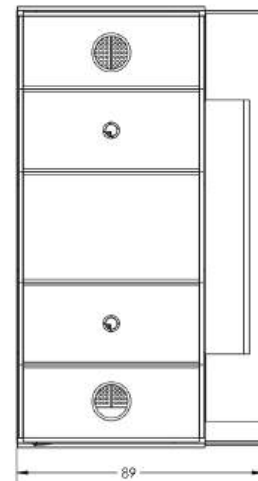

Side View

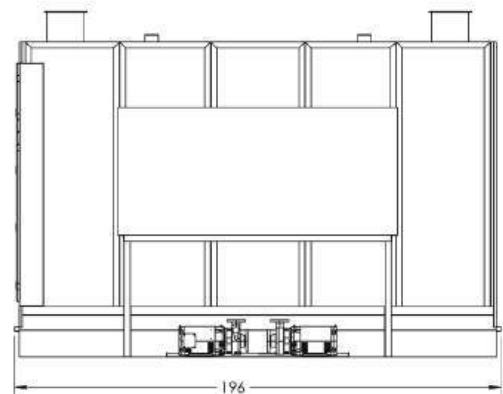



Cage & Rack Washer

Model 430RS

A heavy duty, large-capacity hydro-spray washer that is easy to use, requires minimal maintenance, and has the highest cleanability.

Model	Standard Chamber Size <i>W x H x D</i>	Standard Unit Size <i>W x H x D</i>	Opt. Door Widths	Opt. Door Heights	Opt. Chamber Lengths
430RS	48" x 88" x 188"	62.75" x 95" x 192"	42", 46"	74", 82"	154", 164", 170"

Washers are customizable.

Features

- Heavy-duty Hinge Door
- Modular Construction
- Knock-down Shipment
- **Rotating** Spray Delivery System
- Personnel Safety Features
- PLC Control System with Full Color HMI Touch Screen
- 10 Configurable Cycles
- Automatic Self-cleaning Screen
- Temperature Guarantee
- Insulated Construction
- Incoming Utility Gauges
- Interior Illumination
- SS Recirculation Piping and Components
- Non-proprietary Parts

Construction

The LYNX Brand 430RS Cage and Rack Washers are provided with a heavy-duty stainless steel door with port view glass window.

Recirculated water is heated by a stainless steel steam coil to achieve guaranteed treatment temperatures.

Stainless steel, 20 HP treatment pump with a direct read pump pressure gauge.

Options

- Shallow Base Unit (6")
- Pit or Floor Mounted
- Pass-thru Unit
- Right or Left Hand Services
- Re-usable Throwing Alkaline Tank
- House Hot Water Heat Exchanger
- Integral Data Collection System
- Drain Discharge Cooling
- Automatic Damper
- SS Exhaust Fan
- Low Steam Pressure Package
- Pass-thru Door Interlock System
- Air Compressor
- Printer
- Seismic Tie Down
- Detergent Dispensing Systems
- pH Neutralization System
- Feeder Bottle Washing System
- Automatic Water Rack Flush System
- Split Base for Special Entry
- Utility Enclosure Panels
- Inclined Floor Grating
- Barrier Wall Flange(s)

Accessories

- Floor Ramps
- Bottle Wash Cart
- Universal Cage Wash Cart
- High Capacity Cage Wash System

Utilities

Electrical (E)	3-60-208/480/600V, 23HP
Hot Water (HW)	1" NPT, 35 PSI, 25 GPM @ 140° F ± 5° F (95 gallon sump capacity)
Cold Water (CW)*	1" NPT, 35 PSI, 25 GPM @ 50° F ± 5° F
Steam (S)	2" NPT, 40-60 PSI, Dynamic ± 5 PSI, 900 #/Hr Flow Rate
Condensate (C)	1" NPT + 3/4" NPT
Air (A)	1/4" NPT, 80-100 PSI, 1-2 CFM Flow Rate
Drain (D)	12" x 12" Floor Sink with 4" Floor Drain (<i>minimum</i>), 550 GPM Flow Rate
Vent (V)	8" x 22" Duct, Saturated Vapor @ 190° F, 1 DC (1200 CFM) + 1 IDC (500 CFM)

*CW - Required if drain discharge cool-down package ordered

Drawings

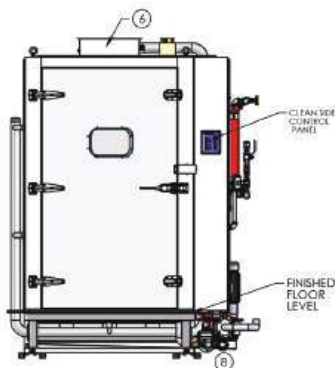
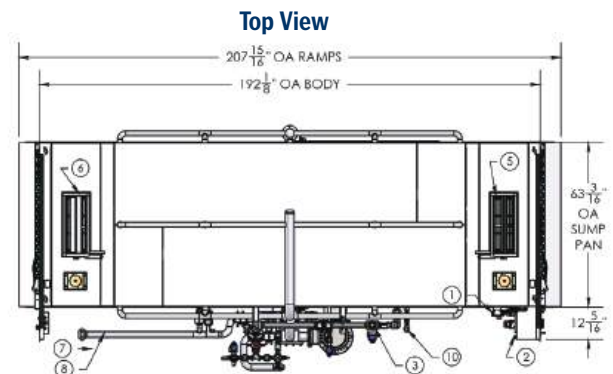
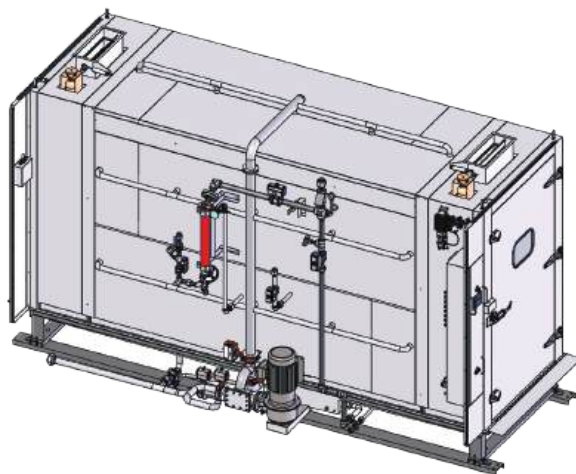

Side View

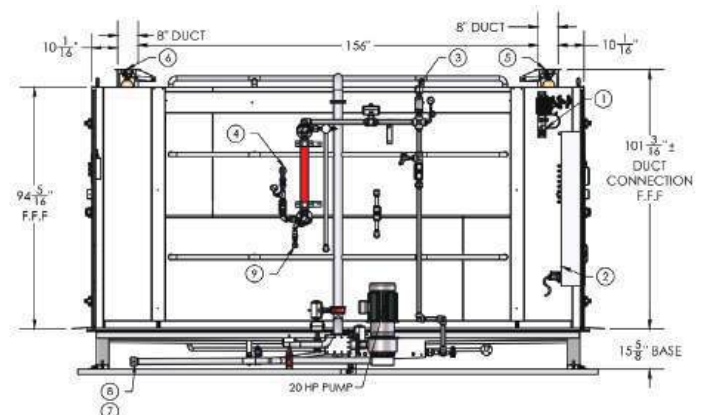

Front View

Spire Integrated Solutions manufactures the LYNX brand of Vivarium Washing equipment.



Cage & Rack Washer

Model 450LX

A heavy duty, large-capacity hydro-spray washer that is easy to use, requires minimal maintenance, and highest cleanability rating.

Model	Standard Chamber Size <i>W x H x D</i>	Standard Unit Size <i>W x H x D</i>	Opt. Door Widths	Opt. Door Heights	Opt. Chamber Lengths
450LX	72" x 85" x 141"	122" x 104" x 149"-226"	60", 84"	88", 93", 96"	All 85"- 188"+

Washers can be designed to any size to meet your application requirements.

Features

- Heavy-duty Hinge Doors
- Modular Construction
- Knock-down Shipment
- Oscillating Spray Delivery System
- Personnel Safety Features
- PLC Control System Full Color HMI Touch Screen
- 12 Configurable Cycles
- Neutralization System
- Automatic Self-cleaning Screen
- Temperature Guarantee
- Insulated Construction
- Incoming Utility Gauges
- Interior Illumination
- SS Recirculation Piping and Components
- Non-proprietary Parts

Construction

Heavy-duty stainless steel doors with double pane glass window.

Recirculated water is heated by a stainless steel steam coil to achieve guaranteed treatment temperatures.

(2) stainless steel 10-15 HP treatment pumps with direct read pump pressure gauges.

Options

- Pit or Floor Mounted
- Pass-thru Unit
- Right or Left Hand Services
- LYNX OPTI-Wash™ Water Saving System
- Re-usable Throwing Alkaline and/or Acid Tank
- Heated Rinse Tank
- House Hot Water Heat Exchanger
- Electric Heat System
- Integral Data Collection System
- LYNX Smart-Cool™ System
- Drain Discharge Cooling - Injected/Tank
- Automatic Damper
- SS Exhaust Fan
- Low Steam Pressure Package
- Pass-thru Door Interlock System
- Air Compressor
- Printer
- Seismic Tie Down
- Detergent Dispensing Systems
- pH Neutralization System
- Feeder Bottle Washing System
- Integrated Pan Wash System
- Automatic Water Rack Flush System
- Split Base for Special Entry
- Port-view Door Window
- 1/3 View Glass Door
- Full View Glass Door
- 36"-54" Door Widths Available (46" wide standard)
- Active Door Seal
- Utility Enclosure Panels
- Inclined Floor Grating
- Automatic Inclined Floor Grating
- Steam Heated Dryer System
- Barrier Wall Flange(s)

Accessories

- Floor Ramps
- Modular Walls
- Bottle Wash Cart
- Universal Cage Wash Cart

Utilities

Electrical (E)	3-60-208/480V, 22-32HP
Hot Water (HW)	1½" NPT, 35 PSI, 50 GPM @ 140° F ± 5° F (40 gallon sump capacity)
Cold Water (CW)*	1½" NPT, 35 PSI, 100 GPM @ 50° F ± 5° F
Steam (S)	2" NPT, 45-80 PSI, Dynamic ± 5 PSI, 1000-1200 #/Hr Flow Rate 2" NPT
Condensate (C)	½" NPT
Air (A)	80-100 PSI, 4-6 CFM Flow Rate
Drain (D)	(2) 12" x 12" Floor Sink with (2) 4" Floor Drain (<i>minimum</i>), 180 GPM Flow Rate
Vent (V)	12" ID Duct, 750 CFM, Saturated Vapor @ 190° F

**CW - Required if drain discharge cool-down package ordered*

Drawings

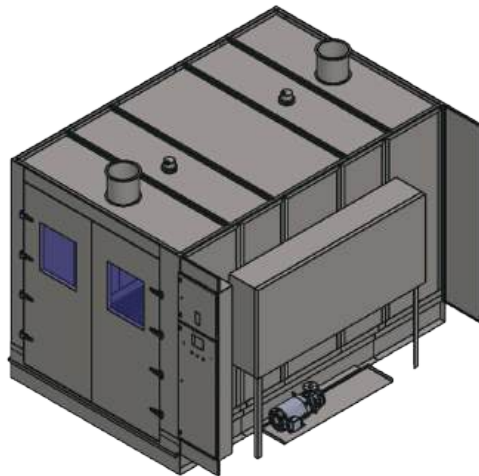

Top View

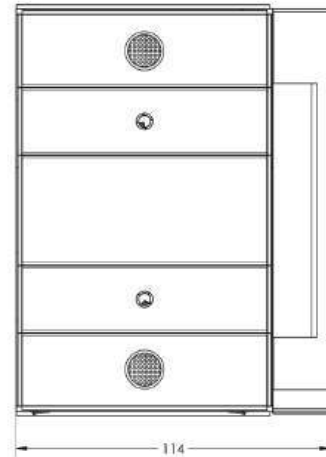

Front View

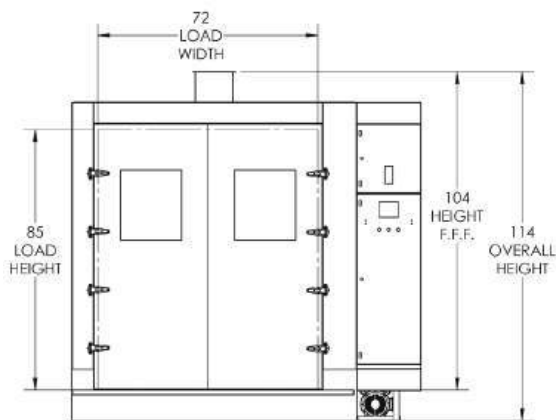

Side View

