

Spire Integrated Solutions manufactures the LYNX brand of Vivarium Washing equipment.



Cage & Rack Washer

Model 410LX

Hydro-spray washers designed for ease of use, minimal maintenance, and highest cleanability of caging, bottles, racks, debris pans, and other items.

| Model | Standard Chamber Size W x H x D (inches) | Standard Unit Size W x H x D (inches) | Opt. Door Widths (inches) | Opt. Door Heights (inches) | Opt. Chamber Lengths (inches) |
|-------|--|---|------------------------------|-------------------------------|----------------------------------|
| 410LX | 46 x 85 x 92 | 89 x 104 x 93-130 | 36, 48, 54 | 88, 93, 96 | 85, 88, 104, 111, 116, 122 |

Washers can be designed to any size to meet your application requirements.

Features

- Heavy-duty Hinge Door
- 1/3rd size viewing glass on door
- Modular construction
- Knock-down shipment
- Oscillating spray delivery system
- Personnel safety features
- LYNX IDEC controls system
- Full color HMI touch screen
- 12 configurable cycles
- Neutralization system
- Automatic self-cleaning screen
- Temperature guarantee
- Insulated construction
- Incoming utility gauges
- Interior illumination
- SS recirculation piping and components
- Recirculated water is heated by a stainless steel steam coil to achieve guaranteed treatment temperatures.
- (2) stainless steel 10 HP treatment pumps with direct read pump pressure gauges.
- Non-proprietary parts

Options

- Shallow Base Unit (6")
- Pit or Floor Mounted
- Pass-thru Unit
- Right or Left Hand Services
- LYNX OPTI-Wash™ Water Saving System
- Re-usable Throwaway Alkaline and/or Acid Tank
- Heated Rinse Tank
- House Hot Water Heat Exchanger
- Electric Heat System
- Integral Data Collection System
- LYNX Smart-Cool™ System
- Drain Discharge Cooling-Injected/Tank
- Automatic Damper
- SS Exhaust Fan
- Low Steam Pressure Package
- Pass-thru Door Interlock System
- Air Compressor
- Printer
- Seismic Tie Down
- Detergent Dispensing Systems
- pH Neutralization System
- Feeder Bottle Washing System
- Integrated Pan Wash System
- Automatic Water Rack Flush System

- 36"-54" Door Widths
- Active Door Seal
- Utility Enclosure Panels
- Inclined Floor Grating
- Automatic Inclined Floor Grating
- Steam Heated Dryer System
- Barrier Wall Flange(s)
- Split Base for Special Entry
- Port-view Door Window

Accessories

- Floor Ramps
- Bottle Wash Cart
- Universal Cage Wash Cart

Construction

- Cabinet Construction - 14 ga 304 SS
- 46" wide standard door

Utilities

| | |
|---------------------------|--|
| Electrical (E) Hot | 3-60-208/480V, 12HP |
| Water (HW) Cold | 1½" NPT, 35 PSI, 50 GPM @ 140° F ± 5° F (40 gallon sump capacity) 1½" NPT, 35 PSI, |
| Water (CW)* | 60 GPM @ 50° F ± 5° F |
| Steam (S) | 2" NPT, 45-80 PSI, Dynamic ± 5 PSI, 800-1200 #/Hr Flow Rate |
| Condensate (C) | 1" NPT |
| Air (A) | ½" NPT, 80-100 PSI, 4-6 CFM Flow Rate |
| Drain (D) | 12" x 12" Floor Sink with 4" Floor Drain (<i>minimum</i>), 180 GPM Flow Rate |
| Vent (V) | 12" ID Duct, 750 CFM, Saturated Vapor @ 190° F |

*CW - Required if drain discharge cool-down package ordered

Drawings

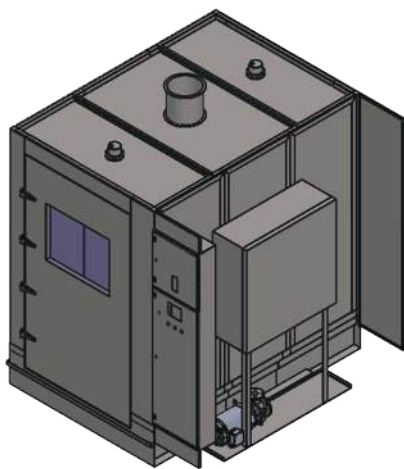

Top View

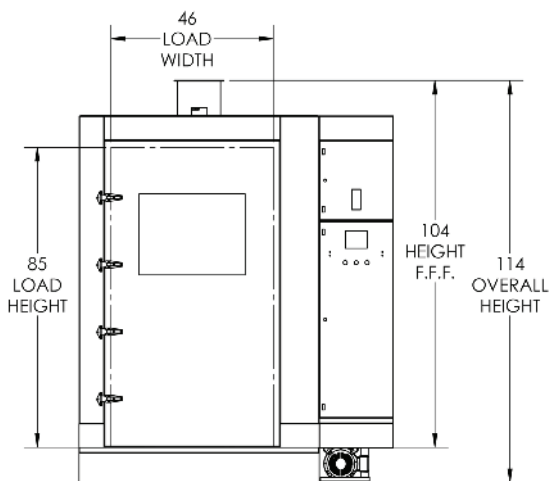
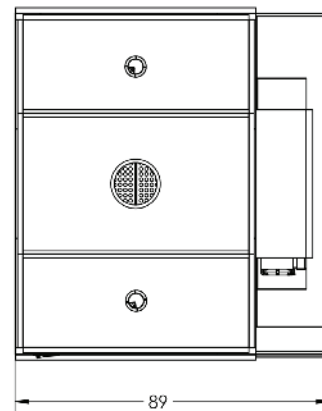

Front View

Side View

