



Cage & Bottle Washers

Model 320RS | 340RS

Hydro-spray washers designed for ease of use, minimal maintenance, and highest cleanability of caging, bottles, debris pans, and other items.

Model	Standard Chamber Size	Standard Unit Size
320RS ¹	45" W x 39" H x 36" D	70" W x 73" H x 42" D
340RS ²	45" W x 39" H x 52" D	70" W x 73" H x 58" D

Features

- Drop-down Door
- Rotating Spray Delivery System
- Personnel Safety Features
- PLC Control System with Full Color HMI Touch Screen
- 10 Configurable Cycles
- Neutralization System
- Automatic Self-cleaning Screen
- Temperature Guarantee
- Insulated Construction
- Incoming Utility Gauges
- Interior Illumination
- SS Recirculation Piping and Components
- Non-proprietary Parts

Construction

The LYNX Brand 320RS and 340RS Cage and Bottle Washers are provided with an all stainless steel drop-down door with glass window.

Recirculated water is heated by a stainless steel steam coil to achieve guaranteed treatment temperatures.

Unit is provided with a stainless steel 7½ HP treatment pump with a direct read pump pressure gauge.

Options

- Pass-thru Unit
- Right or Left Hand Services
- House Hot Water Heat Exchanger
- Electric Heat System
- Drain Discharge Cooling - Injected
- Automatic Damper
- Exhaust Fan
- Low Steam Pressure Package
- Devapourmatic System (no exterior exhaust)
- Pass-thru Door Interlock System
- Air Compressor
- Integral Data Collection System
- Printer
- Seismic Tie Down
- Detergent Dispensing Systems
- pH Neutralization Monitoring System
- Direct DI or pure water final rinse
- Barrier Wall Flange(s)

Accessories

- High Capacity Center Header System (accessory)
- Cage Wash Rack
- Bottle Wash Rack
- Transfer Cart

Utilities

Electrical (E)	3-60-208/480/600V, 10 HP
Hot Water (HW)	1" NPT, 35 PSI, 25 GPM @ 120° F ± 5° F
Cold Water (CW)*	¾" NPT, 35 PSI, 25 GPM @ 50° F ± 5° F
Steam (S)	1" NPT, 60 PSI, Dynamic ± 5 PSI, 350-600 #/Hr Flow Rate ¾" NPT
Condensate (C)	¼" NPT, 80-100 PSI
Air (A)	1-2 CFM Flow Rate
Drain (D)	4" Floor Drain (<i>minimum</i>), 90 GPM Flow Rate
Vent (V)	15" x 4½" Duct, 400 CFM, Saturated Vapor @ 190° F

*CW - Required if drain discharge cool-down package ordered

Drawings

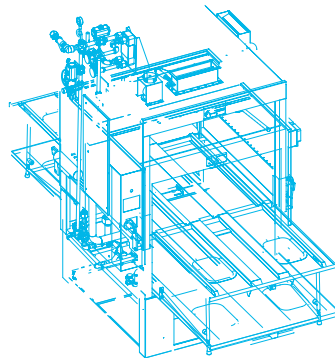

Front View

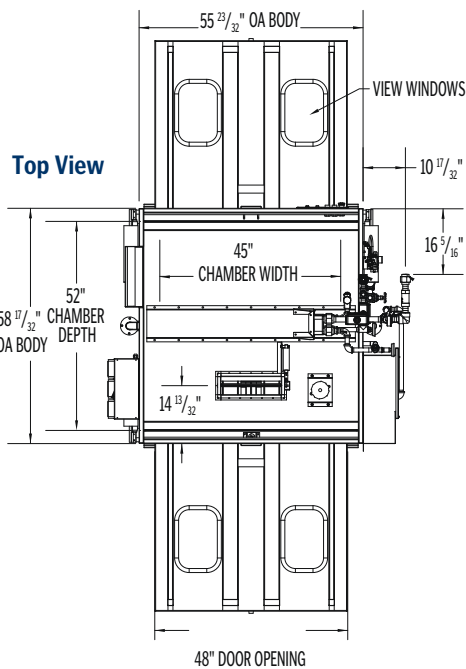
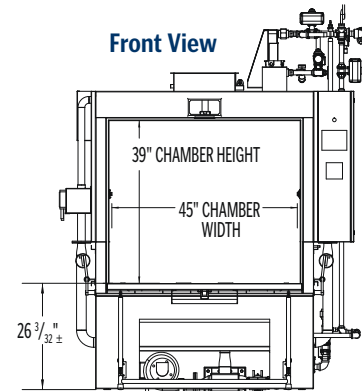

Top View

Side View

