

Spire Integrated Solutions manufactures the LYNX brand of Vivarium Washing equipment.

Cage & Bottle Washers

Model 310LX | 330LX

Customizable, hydro-spray washers designed for ease of use, minimal maintenance, and high throughput.



12 configurable cycles

Model	Standard Chamber Size	Standard Unit Size
310LX	48" W x 32" H x 34" D	72" W x 82" H x 39" D
330LX	48" W x 32" H x 48" D	72" W x 82" H x 52.5" D

Features

- 12 configurable cycles
- Vertical rise sliding door
- Oscillating spray delivery system
- Recirculated water is heated by a stainless steel steam coil to achieve guaranteed treatment temperatures.
- Stainless steel 7.5 HP treatment pump with a direct read pump pressure gauge.
- Personnel safety features
- PLC control system with color HMI Touch Screen
- Neutralization system
- Automatic self-cleaning Screen
- Temperature guarantee
- Incoming utility gauges

Construction

- Stainless steel vertical rise door
- Double pane glass window
- Insulated
- Interior illumination
- Stainless steel recirculation piping and components

Options

- Pass-thru unit
- Right or left hand services
- LYNX OPTI-Wash™ water saving system
- High capacity center header system
- House hot water heat exchanger
- Electric heat system
- LYNX Smart-Cool™ system
- Drain discharge cooling - Injected
- Effluent surge tank
- Automatic damper
- Exhaust fan
- Low steam pressure package
- Non-vented, vapor condenser
- Pass-thru door interlock system
- Air compressor
- Integral data collection system
- Printer
- Seismic tie down
- Detergent dispensing systems
- pH neutralization monitoring system
- Direct DI or pure water final rinse
- Barrier wall flange(s)

Accessories

- Cage wash rack
- Bottle wash rack
- Transfer cart

Utilities

Electrical (E)	3-60-208/480V, 9HP
Hot Water (HW)	1" NPT, 35 PSI, 30 GPM @ 140° F ± 5° F
Cold Water (CW)*	1" NPT, 50 PSI, 40 GPM @ 50° F ± 5° F
Steam (S)	1½" NPT, 45-80 PSI, 350-600 #/Hr Flow Rate
Condensate (C)	1" NPT
Air (A)	½" NPT, 80-100 PSI, 2-4 CFM Flow Rate
Drain (D)	4" Floor Drain (<i>minimum</i>), 90 GPM Flow Rate
Vent (V)	8" ID Duct, 200 CFM, Saturated Vapor @ 190° F

**CW - Required if drain discharge cool-down package ordered
Washers can be designed to any size to meet your application requirements.*

Drawings

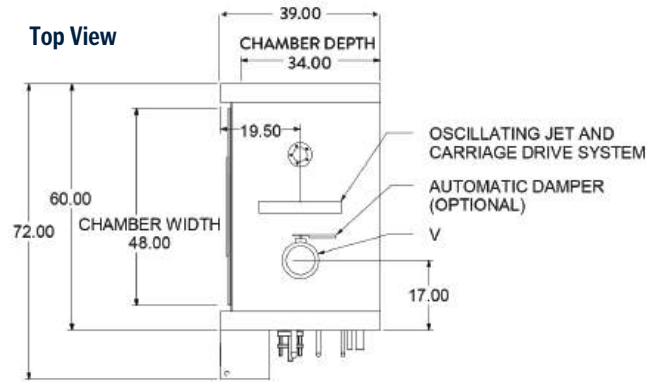
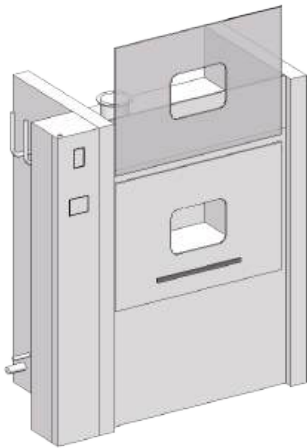

Front View

