



2026 Morgue Cold Storage Equipment Catalog



CSI JEWETT
SPIRE INTEGRATED SOLUTIONS

Spire Integrated Solutions manufactures the CSI Jewett brand of morgue refrigeration equipment.

[Walk-in refrigeration systems](#)



Click on the link to jump to its page.

[Options & accessories](#)

[End-acting morgues](#)

[End-acting remote series morgues](#)

[Roll-in acting morgues](#)

[Side-acting morgues](#)

[Configurable storage racks](#)

[Concealed transport carts](#)

[About installation](#)

[Cadaver handling equipment catalog](#)



CSI Jewett walk-in refrigerators offer high-volume, precisely controlled cold storage. Their compartmentalized design allows you to select the optimal, customizable unit for your unique application. The prefabricated panel construction allows for easy on-site assembly and future expansion.



Specifications

- Temp range 35-42° F.
- Refrigeration is a self-contained combination package system with R404a refrigerant.
- Nominal 4" foamed-in-place, polyurethane insulation.
- Temperature stability
- The front is manufactured with 20 gauge (0.91 mm) type 304 #4 finish polished stainless steel.
- Easy to clean
- Floor - 20-gauge galvanized steel.
- Corrosion-resistant floor
- The sides, back, top, walls, and ceilings comprise .032" (0.81 mm) stucco embossed aluminum.
- The standard 3-piece telescoping tray carriage assembly provides full extension during operation.
- Each compartment comes with an MT1 tray, which has a 500-pound capacity.
- Compartmentalized designs include end-opening, side-opening, roll-in, and end-opening/roll-in combinations, with pass-through applications for loading and unloading in separate rooms.

Options

- Door heater
- Chrome-plated hardware
- Keyed latch
- Cardholder
- Dart style gasket (replaceable)
- Choice of self-contained or remote mechanical system.
- Morgue Autopsy Planning (MAP) service.
- Ceiling composed of stucco embossed aluminum.
- Tongue-in-groove style panels for sure-fitting.
- Tight-seal wall construction
- Hermetically sealed compressors
- Engineered refrigeration systems
- Temperature uniformity
- Heavy-gauge, polished stainless steel (sides, backs, tops, interior walls)
- Customizable equipment capacities and configurations from one body to hundreds.
- Fast response to changes in cabinet temperature, ambient conditions, product loadings, and door openings.

More Refrigeration Options

- Bariatric Configurations
- Pass-through Configurations
- Lighting Fixture with Pilot Switch
- Stainless Steel Interior
- Stainless Steel Exterior
- Stainless Steel Trim Enclosure Panels
- Painted and Alternate Finishes
- Model DTPM Temperature and Power Monitoring System
- Model 7ER Circular Seven Day Chart Recorder
- Outdoor Mounted Condensing Unit
- Remote Air or Water Cooled Condensing Unit
- Freezer Application
- Alternate Electrical
- Opposite Door Swing (right-handed is standard)
- Roller Frame Tray Rails with Anti-tilt For Compatibility With CSI Jewett Body Transport Systems
- Single Full Height Doors
- Dual Mechanical 100 Percent Back-up With Auto-switchover



LED Interior Light

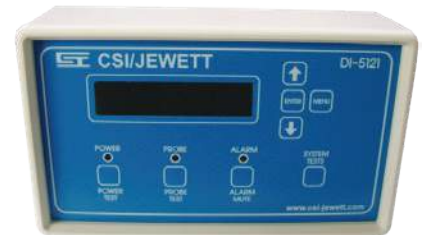

DTPM Temperature and Power Monitor



EBR Elevating Body Rack for use with roller pallet carts and lifters.



Model 7ER Chart Recorder

End Acting Morgues - EC Series

- CSI Jewett traditional style End-Opening Morgue Refrigerators provide individualized compartments for bodies and full-extension carriages for front loading and storage.
- The self contained package refrigeration allows for ease of installation and service.
- One to twelve body capacity is standard for the EC Series. Larger capacities are available.



Model 12EC4W with cadaver lifter

Dimensions

MODEL	W x D x H inches	Body Capacity
1EC	84.5 x 39 x 47.75	1
2EC	84.5 x 39 x 73.75	2
3EC	84.5 x 39 x 95.25	3
4EC2W	84.5 x 73 x 76	4
6EC2W	84.5 x 73 x 101.25	6
6EC3W	84.5 x 106.75 x 76	6
8EC2W	84.5 x 73 x 97.5	8
8EC4W	84.5 x 141 x 77.5	8
9EC3W	84.5 x 107 x 99.5	9
12EC3W	84.5 x 107 x 99	12
12EC4W	84.5 x 141 x 103.25	12

Top View

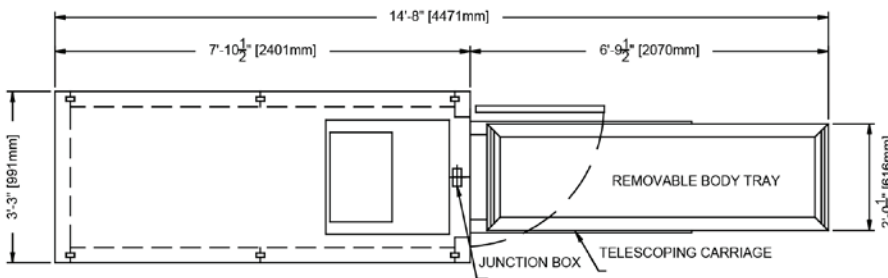

Model 12EC4W with concealed transport cart

Front View

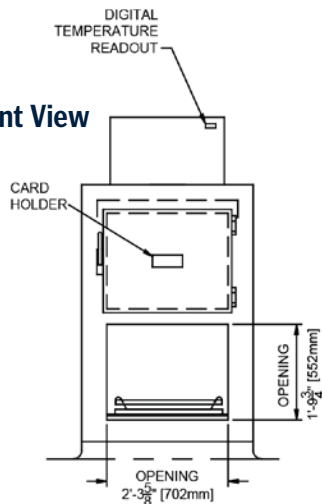

Side View

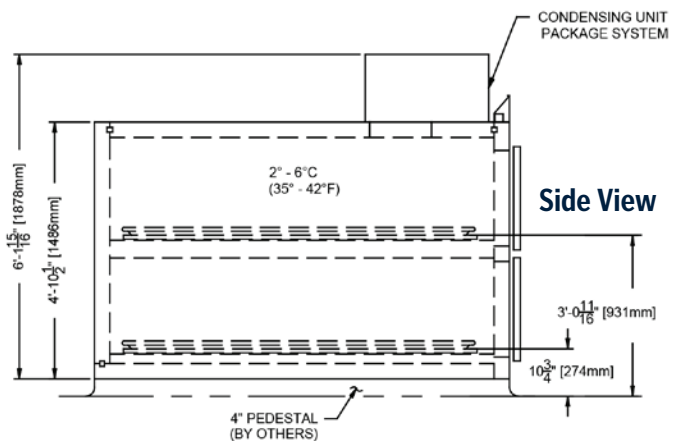

- CSI Jewett traditional style End-Opening Morgue Refrigerators provide individualized compartments for bodies and full-extension carriages for front loading and storage.
- One to twelve body capacity is standard for the Remote Series. Customizable capacities available.
- Traditional remote-split refrigeration provides great flexibility for installation and retrofit of equipment.

MODEL	Dimensions	
	W x D x H inches	
		Body Capacity
1R1W	84.5 x 39 x 55.75	1
2R1W	84.5 x 39 x 81	2
3R1W	84.5 x 39 x 95.25	3
4R2W	84.5 x 73 x 82.5	4
6R2W	84.5 x 73 x 106.25	6
6R3W	84.5 x 107 x 82.5	6
8R2W	84.5 x 73 x 97.75	8
8R4W	84.5 x 141 x 82.5	8
9R3W	84.5 x 107 x 106.25	9
12R3W	84.5 x 107 x 103.75	12
12R4W	84.5 x 141 x 105.25	12



Model 6R2W

Top View

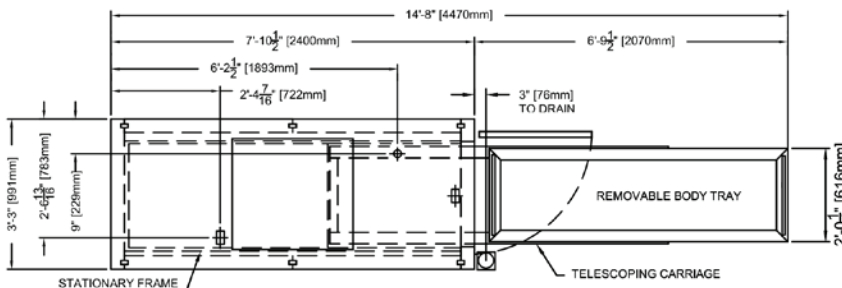

Front View

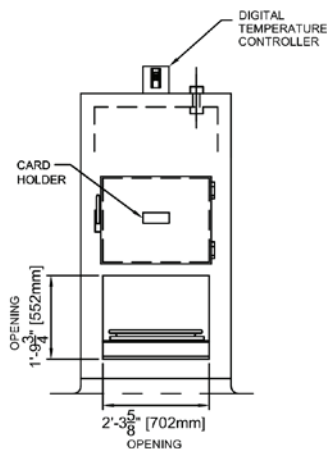

Side View

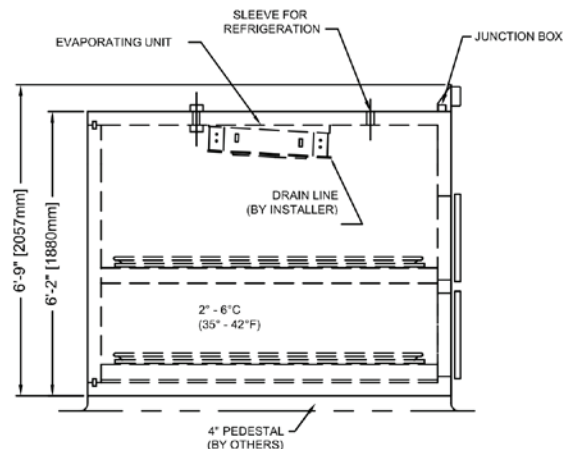

Roll In Morgues - SP/SPEC Series

- CSI Jewett brand Roll-In Morgue Refrigerators provide simple, cart style loading convenience.
- Compartments are designed to hold up to 2 bodies each when using an optional CSI Jewett MC2 series cart.
- Combination Roll-In/End-Opening morgue refrigerators provide the convenience of roll in body storage plus the added benefit of additional storage in individualized compartments for bodies and parts in an upper compartment.
- The upper compartment features full-extension carriages for front loading and storage.
- Standard capacities run from two to twelve bodies. Greater capacities are available.
- Refrigerators are available with either a self contained refrigeration system (SPEC series) or split remote refrigeration (SP Series).

ROLL IN MORGUES		
MODEL	Dimensions	
	<i>W x D x H</i> <i>inches</i>	Body Capacity
2SP1W	39 x 94.5 x 82.5	2
2SPEC1W	39 x 94.5 x 70.5	2
4SP2W	73 x 94.5 x 82.5	4
4SPEC2W	73 x 94.5 x 72.25	4
6SP3W	109.5 x 80 x 94.5	6
6SPEC3W	109.5 x 94.5 x 76	6
8SP4W	145 x 94.5 x 82.5	8
8SPEC4W	145 x 94.5 x 76	8

ROLL IN/END OPENING COMBINATION MORGUES		
MODEL	Dimensions	
	<i>W x D x H</i> <i>inches</i>	Body Capacity
3SP1W	39 x 94.5 x 104.3	3
3SPEC1W	39 x 94.5 x 97.5	3
6SP2W	73 x 105.5 x 94.5	6
6SPEC2W	73 x 94.5 x 99	6
9SP3W	109.5 x 94.5 x 104.3	9
9SPEC3W	109.5 x 94.5 x 99	9



Model 6SP3W

- CSI Jewett Side-Acting Morgue Refrigerators provide individualized compartments for bodies and exclusive full-extension roller frame carriages for front loading and storage.
- These side opening models are ideal for locations where space does not allow for end-operated access.
- The self contained package refrigeration allows for ease of installation and service.
- Standard capacities run from one to three bodies. Customizable capacities available.
- Remote Refrigeration option available.



Model 3SC

MODEL	Dimensions	
	W x D x H inches	Body Capacity
1SC	94.5 x 39 x 51.25	1
2SC	94.5 x 39 x 76	2
3SC	94.5 x 39 x 104.6	3

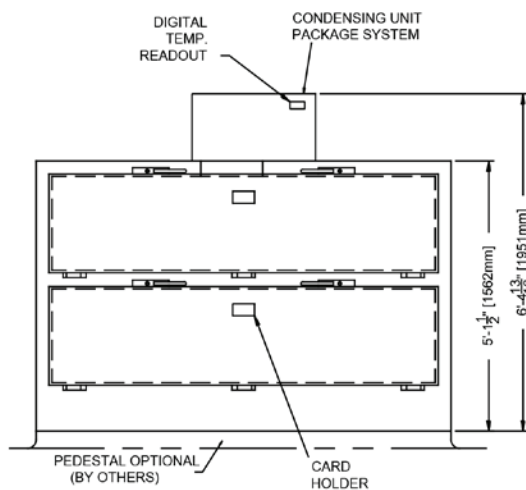
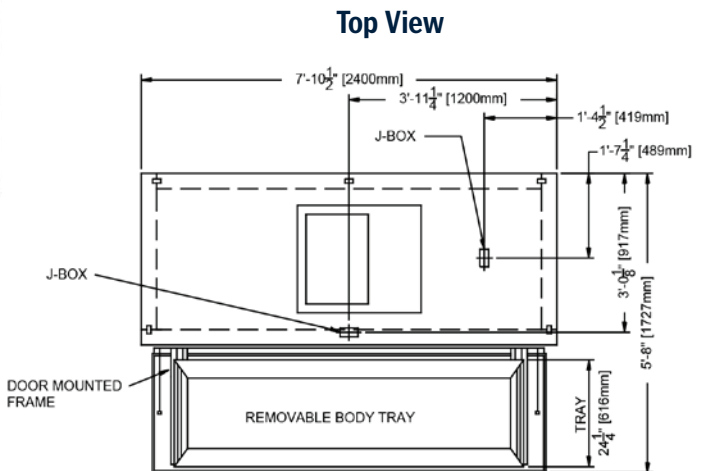

Front View

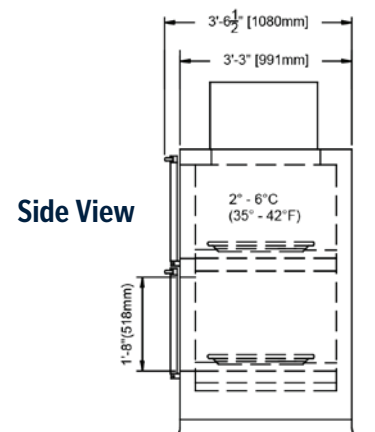

Side View

2SC drawing shown, consult your representative for additional model drawings.

Configurable Storage Rack Systems

Large capacity, configurable storage racks compatible with CSI Jewett brand MT Series body trays, plus other manufacturer's trays.

Available with 2-4 tiers and include either MT1 or MT2 tray.

- **2000lbs. capacity total**
- Constructed of type 304 stainless steel.
- All seams are fully-welded and polished.
- Roller frame is a formed, single piece construction, has full length, anti-tilt retainer channels, and Killian zinc-plated roller bearings.
- Configurable storage racks compatible with MT Series Body Trays and other manufacturer's trays.
- 6" diameter swivel type casters with polyurethane tires.



Automatic pivoting tray lock system secures the tray in place.



(4) tier racks

Includes four (4) MT2 body trays

SR1211-2-22

34" x 75" x 84.25"

SR1211-2

28" x 75" x 84"

(2) tier racks

SR1211-25

Includes (2) MT2 body trays

28" x 42.88" x 84.25"

SR1211-2-21

Includes (2) MT1 body trays

34" x 42.88" x 84.25"

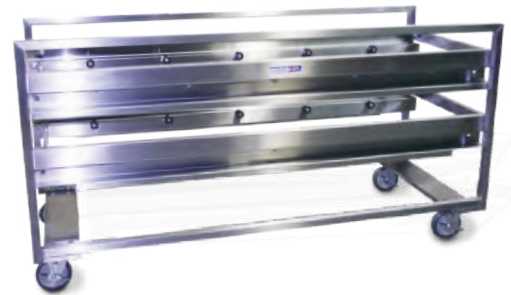

Manual & Hydraulic Lift Concealed Transport Carts

These lightweight, easily maneuverable carts feature adjustable height for bedside transfer, a concealed tray, and a cover to maintain discretion during transport.

The cart's oversized casters and aluminum construction minimize strain on the staff.



CCT3687

Concealment cover (optional)

FEATURES

- Designed and crafted in the U.S.A.
- 3 tray size choices
- Sizes range 30" x 84"- 40.1" x 84"
- Lightweight
- 5" to 8" swivel casters available.
- Manual, battery powered, and hydraulic crank types available.
- Various tray types (included).
- Minimal effort to the bedside.
- Hand crank various height adjustment.
- Bariatric-size morgue equipment concealed transport carts available.

DIMENSIONS

Model	Sizes	Adj. Height*	Included Tray Type	Capacity	Crank Type	Caster Size	Rollers	Saddle Tray	Fixed Top
CCT101	30" x 84"	18.5" to 31.8"	MT1	300 lbs.	Manual	6		Y	
CCT102R-MT2	34.1" x 84"	29.6" to 35.6"	MT2	1000 lbs.	Manual	8	Y		
CCT102-MT1	28.3" x 84"	29.6" to 35.6"	MT1	800 lbs.	Manual	8	Y		
CCT200	28.3" X 87"	13.5" to 38"	MT1	500 lbs.	Battery powered	5	Opt	Opt	Opt
CCT3687	28.3" x 84"	27.4" to 33.4"	MT1	1000 lbs.	Hydraulic lift	8		Y	
CCT3687B	34.1" x 84"	27.4" to 33.4"	MT2	1000 lbs.	Hydraulic lift	8		Y	
CCT4087	40.1" x 84"	27.5" to 33.5"	MT4	1000 lbs.	Hydraulic lift	8		Y	

*With frame range measured from bottom of tray

Factory installation is available if needed for your application. SPIRE Integrated Solutions' expert project management team will collaborate with you from initial sale to final commissioning of equipment, helping to manage every aspect of your installation project ensuring seamless integration within your facility.

Project Milestones

- Site Pre-installation Inspection (if needed)
- Site Supervision of Unloading and Rigging
- Reassembly of MEP Components Removed for Rigging
- Coordination with On-site Contractors for MEP Connections
- Startup and On-site Equipment Testing
- User Training

OUR INSTALLATION PROMISE

The manufacturing, delivering and installation of your refrigeration equipment will be on schedule and ready for use.

Spire Integrated Solutions takes care of the start-to-finish project management all the way up to installation including equipment placement and comprehensive testing to managing contractors.

Spire Integrated Solutions manufactures the CSI Jewett brand of morgue refrigeration equipment - made in America.



Ask us about



CSI JEWETT

SPIRE INTEGRATED SOLUTIONS



Cadaver Handling Equipment

Spire Integrated Solutions manufactures the CSI Jewett brand of Cadaver Handling equipment.

Mobile storage carts



Mobile autopsy tables



Manual & Hydraulic cadaver lifters



Fixed & Removable tray transport carts



Fixed & Configurable storage rack systems



7936 Forest City Road . Orlando FL 32810 | healthcareteam@spire-is.com | 877 679 7800 | spire-is.com