

LYNX

Cage & Rack Washers

Model 410LX



Ensuring efficient cleaning for all your animal care items

The LYNX Model 410LX Cage and Rack Washers are heavy duty, large capacity reliable hydro-spray washers designed for ease of use, minimal maintenance, and highest cleanability of caging, bottles, racks, debris pans, and other items used in the care of laboratory animals. These washers deliver high performance within a simplistic design. The system is provided with greater flexibility to meet today's "green" initiatives and high throughput demands. LYNX standardizes on non-proprietary parts on all equipment. Pit mounting is standard.

Standard Features

- Heavy-duty Hinge Door
- Modular Construction
- Knock-down Shipment
- **Oscillating** Spray Delivery System
- Personnel Safety Features
- PLC Control System with Full Color HMI Touch Screen
- 12 Configurable Cycles
- Neutralization System
- Automatic Self-cleaning Screen
- Temperature Guarantee
- Insulated Construction
- Incoming Utility Gauges
- Interior Illumination
- SS Recirculation Piping and Components
- Non-proprietary Parts

Construction

LYNX 410LX Cage and Rack Washers are provided with a heavy-duty stainless steel door with double pane glass window. Recirculated water is heated by a stainless steel steam coil to achieve guaranteed treatment temperatures. A color touch screen control panel provides a user-friendly interface for selecting, programming, and monitoring cycles. Unit is provided with a stainless steel 10 HP treatment pump with a direct read pump pressure gauge.

Optional Features

- **Shallow Base Unit** (6")
- Pit or Floor Mounted
- Pass-thru Unit
- Right or Left Hand Services
- LYNX OPTI-Wash™ Water Saving System
- Re-usable Throwaway Alkaline and/or Acid Tank
- Heated Rinse Tank
- House Hot Water Heat Exchanger
- Electric Heat System
- Integral Data Collection System
- LYNX Smart-Cool™ System
- Drain Discharge Cooling - Injected/Tank
- Automatic Damper
- SS Exhaust Fan
- Low Steam Pressure Package
- Pass-thru Door Interlock System
- Air Compressor
- Printer
- Seismic Tie Down
- Detergent Dispensing Systems
- pH Neutralization System
- Feeder Bottle Washing System

Optional Features *cont*

- Integrated Pan Wash System
- Automatic Water Rack Flush System
- Split Base for Special Entry
- Port-view Door Window
- 1/3 View Glass Door
- Full View Glass Door
- 36"-54" Door Widths Available (46" wide standard)
- Active Door Seal
- Utility Enclosure Panels
- Inclined Floor Grating
- Automatic Inclined Floor Grating
- Steam Heated Dryer System
- Barrier Wall Flange(s)

Accessories

- Floor Ramps
- Bottle Wash Cart
- Universal Cage Wash Cart

Utilities

Electrical (E)	3-60-208/480V, 12HP
Hot Water (HW)	1½" NPT, 35 PSI, 50 GPM @ 140° F ± 5° F (40 gallon sump capacity)
Cold Water (CW)*	1½" NPT, 35 PSI, 60 GPM @ 50° F ± 5° F
Steam (S)	2" NPT, 45-80 PSI, Dynamic ± 5 PSI, 800-1200 #/Hr Flow Rate
Condensate (C)	1" NPT
Air (A)	½" NPT, 80-100 PSI, 4-6 CFM Flow Rate
Drain (D)	12" x 12" Floor Sink with 4" Floor Drain (<i>minimum</i>), 180 GPM Flow Rate
Vent (V)	12" ID Duct, 750 CFM, Saturated Vapor @ 190° F

*CW - Required if drain discharge cool-down package ordered

Model	Standard Chamber Size W x H x D	Standard Unit Size W x H x D	Opt. Door Widths	Opt. Door Heights	Opt. Chamber Lengths
410LX	46" x 85" x 92"	89" x 104" x 93"-130"	36", 48", 54"	88", 93", 96"	85", 88", 104", 111", 116", 122"

Washers can be designed to any size to meet your application requirements.

Representative Drawings

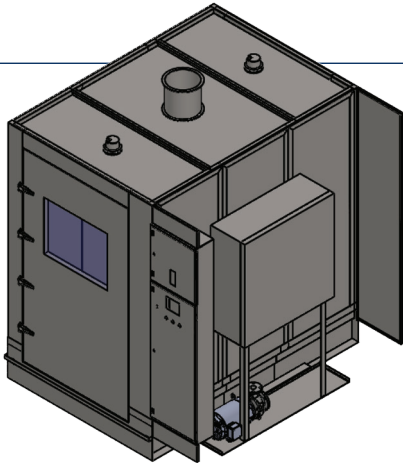

Top View

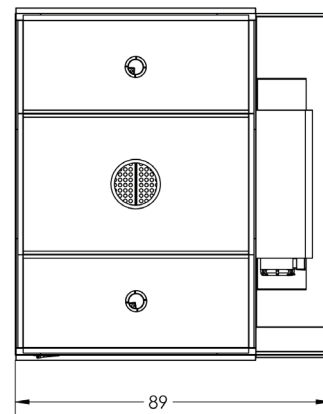

Front View

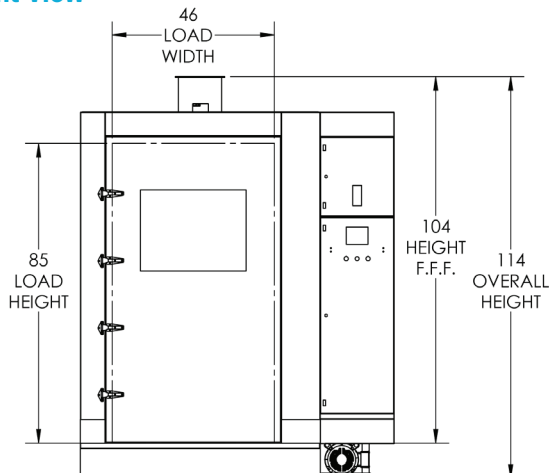

Side View

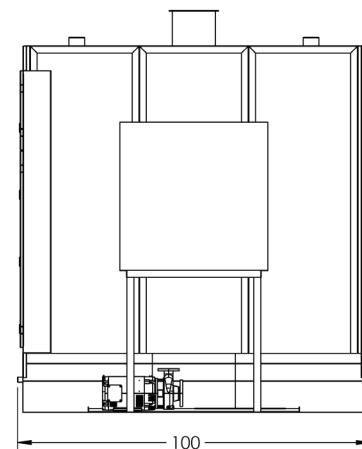

410LX Cage and Rack Washer Sell Sheet_M1024_1.00 2021-0318



LYNX

Cage & Rack Washers

Model 410RS

Ensuring efficient cleaning for all your animal care items

The LYNX Model 410RS (formerly Scientek SW6100/SW6200/SW6300) Cage and Rack Washers are heavy duty, large capacity reliable hydro-spray washers designed for ease of use, minimal maintenance, and highest cleanability of caging, bottles, racks, debris pans, and other items used in the care of laboratory animals. These washers deliver high performance within a simplistic design. The system is provided with greater flexibility to meet today's "green" initiatives and high throughput demands. LYNX standardizes on non-proprietary parts on all equipment. Pit mounting is standard.

Standard Features

- Heavy-duty Hinge Door
- Modular Construction
- Knock-down Shipment
- **Rotating** Spray Delivery System
- Personnel Safety Features
- PLC Control System with Full Color HMI Touch Screen
- 10 Configurable Cycles
- Automatic Self-cleaning Screen
- Temperature Guarantee
- Insulated Construction
- Incoming Utility Gauges
- Interior Illumination
- SS Recirculation Piping and Components
- Non-proprietary Parts

Construction

LYNX 410RS Cage and Rack Washers are provided with a heavy-duty stainless steel door with port view glass window. Recirculated water is heated by a stainless steel steam coil to achieve guaranteed treatment temperatures. A color touch screen control panel provides a user-friendly interface for selecting, programming, and monitoring cycles. Unit is provided with a stainless steel 10 HP treatment pump with a direct read pump pressure gauge.

Optional Features

- **Shallow Base Unit** (6")
- Pit or Floor Mounted
- Pass-thru Unit
- Right or Left Hand Services
- Re-usable Throwaway Alkaline Tank
- House Hot Water Heat Exchanger
- Integral Data Collection System
- Drain Discharge Cooling
- Automatic Damper
- SS Exhaust Fan
- Low Steam Pressure Package
- Pass-thru Door Interlock System
- Air Compressor
- Printer
- Seismic Tie Down
- Detergent Dispensing Systems
- pH Neutralization System
- Feeder Bottle Washing System
- Automatic Water Rack Flush System
- Split Base for Special Entry
- Utility Enclosure Panels
- Inclined Floor Grating
- Barrier Wall Flange(s)

Accessories

- Floor Ramps
- Bottle Wash Cart
- Universal Cage Wash Cart
- High Capacity Cage Wash System

Utilities

Electrical (E)	3-60-208/480/600V, 12HP
Hot Water (HW)	1" NPT, 35 PSI, 25 GPM @ 140° F ± 5° F (65 gallon sump capacity)
Cold Water (CW)*	1" NPT, 35 PSI, 25 GPM @ 50° F ± 5° F
Steam (S)	1½" NPT, 40-60 PSI, Dynamic ± 5 PSI, 450-600 #/Hr Flow Rate
Condensate (C)	¾" NPT
Air (A)	¼" NPT, 80-100 PSI, 1-2 CFM Flow Rate
Drain (D)	12" x 12" Floor Sink with 4" Floor Drain (<i>minimum</i>), 180 GPM Flow Rate
Vent (V)	8" x 13" Duct, Saturated Vapor @ 190° F, 1 DC (1200 CFM) + 1 IDC (500 CFM)

*CW - Required if drain discharge cool-down package ordered

Model	Standard Chamber Size W x H x D	Standard Unit Size W x H x D	Opt. Door Widths	Opt. Door Heights	Opt. Chamber Lengths
410RS ¹	48" x 88" x 96"	88" x 95" x 98"-116"	36", 42", 46"	74", 82"	90", 100", 108"

Washers can be designed to any size to meet your application requirements. Certain options can increase unit sizes.

1) 410RS (formerly Scientek SW6100/SW6200/SW6300)

Representative Drawing

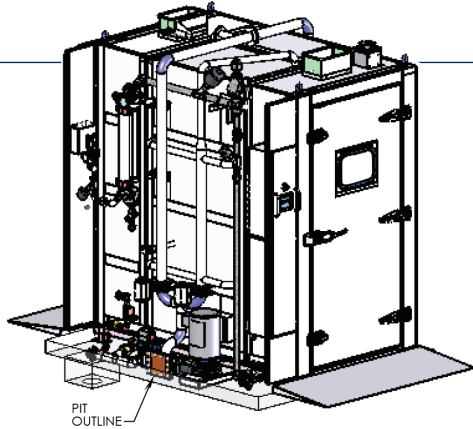

Top View

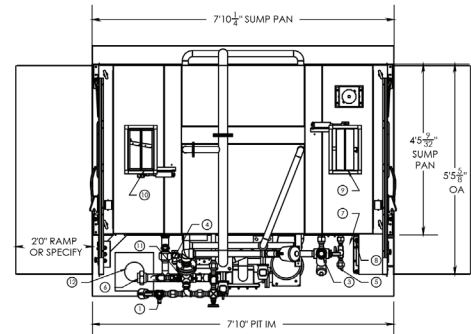

Front View

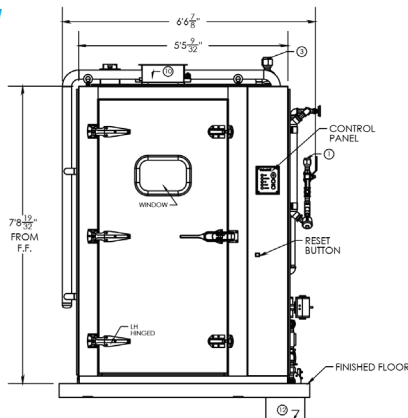

Side View

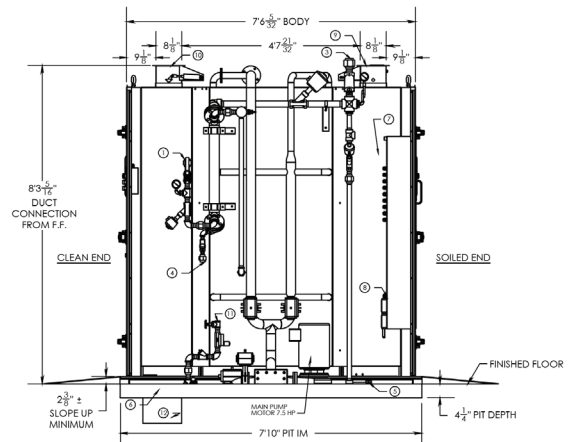

410RS Cage and Rack Washer Sell Sheet_M1040_1.00 2021-0318

LYNX

Cage & Rack Washers

Model 420LX



Ensuring efficient cleaning for all your animal care items

The LYNX Model 420LX Cage and Rack Washers are heavy duty, large capacity reliable hydro-spray washers designed for ease of use, minimal maintenance, and highest cleanability of caging, bottles, racks, debris pans, and other items used in the care of laboratory animals. These washers deliver high performance within a simplistic design. The system is provided with greater flexibility to meet today's "green" initiatives and high throughput demands. LYNX standardizes on non-proprietary parts on all equipment. Pit mounting is standard.

Standard Features

- Heavy-duty Hinge Door
- Modular Construction
- Knock-down Shipment
- **Oscillating** Spray Delivery System
- Personnel Safety Features
- PLC Control System with Full Color HMI Touch Screen
- 12 Configurable Cycles
- Neutralization System
- Automatic Self-cleaning Screen
- Temperature Guarantee
- Insulated Construction
- Incoming Utility Gauges
- Interior Illumination
- SS Recirculation Piping and Components
- Non-proprietary Parts

Construction

LYNX 420LX Cage and Rack Washers are provided with a heavy-duty stainless steel door with double pane glass window. Recirculated water is heated by a stainless steel steam coil to achieve guaranteed treatment temperatures. A color touch screen control panel provides a user-friendly interface for selecting, programming, and monitoring cycles. Unit is provided with a stainless steel 15 HP treatment pump with a direct read pump pressure gauge.

Optional Features

- **Shallow Base Unit** (6")
- Pit or Floor Mounted
- Pass-thru Unit
- Right or Left Hand Services
- LYNX OPTI-Wash™ Water Saving System
- Re-usable Throwaway Alkaline and/or Acid Tank
- Heated Rinse Tank
- House Hot Water Heat Exchanger
- Electric Heat System
- Integral Data Collection System
- LYNX Smart-Cool™ System
- Drain Discharge Cooling - Injected/Tank
- Automatic Damper
- SS Exhaust Fan
- Low Steam Pressure Package
- Pass-thru Door Interlock System
- Air Compressor
- Printer
- Seismic Tie Down
- Detergent Dispensing Systems
- pH Neutralization System
- Feeder Bottle Washing System

Optional Features *cont*

- Integrated Pan Wash System
- Automatic Water Rack Flush System
- Split Base for Special Entry
- Port-view Door Window
- 1/3 View Glass Door
- Full View Glass Door
- 36"-54" Door Widths Available (46" wide standard)
- Active Door Seal
- Utility Enclosure Panels
- Inclined Floor Grating
- Automatic Inclined Floor Grating
- Steam Heated Dryer System
- Barrier Wall Flange(s)

Accessories

- Floor Ramps
- Modular Walls
- Bottle Wash Cart
- Universal Cage Wash Cart

Utilities

Electrical (E)	3-60-208/480V, 17HP
Hot Water (HW)	1½" NPT, 35 PSI, 50 GPM @ 140° F ± 5° F (40 gallon sump capacity)
Cold Water (CW)*	1½" NPT, 35 PSI, 60 GPM @ 50° F ± 5° F
Steam (S)	2" NPT, 45-80 PSI, Dynamic ± 5 PSI, 800-1200 #/Hr Flow Rate
Condensate (C)	1" NPT
Air (A)	½" NPT, 80-100 PSI, 4-6 CFM Flow Rate
Drain (D)	12" x 12" Floor Sink with 4" Floor Drain (<i>minimum</i>), 180 GPM Flow Rate
Vent (V)	12" ID Duct, 750 CFM, Saturated Vapor @ 190° F

*CW - Required if drain discharge cool-down package ordered

Model	Standard Chamber Size W x H x D	Standard Unit Size W x H x D	Opt. Door Widths	Opt. Door Heights	Opt. Chamber Lengths
420LX	46" x 85" x 141"	89" x 104" x 149"	36", 48", 54"	88", 93", 96"	135", 146"

Washers can be designed to any size to meet your application requirements.

Representative Drawings

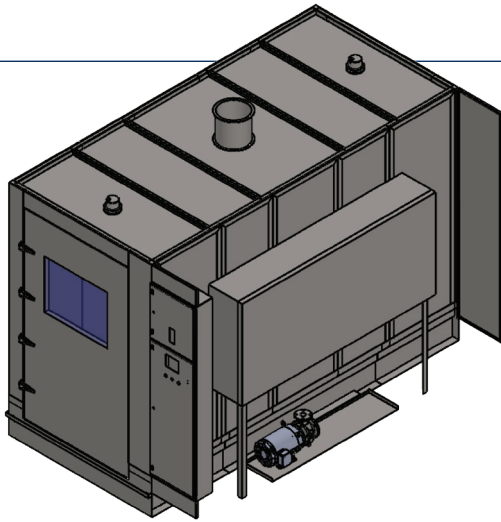

Top View

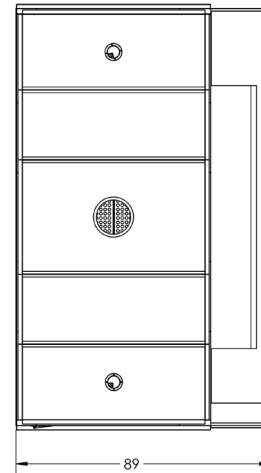

Front View

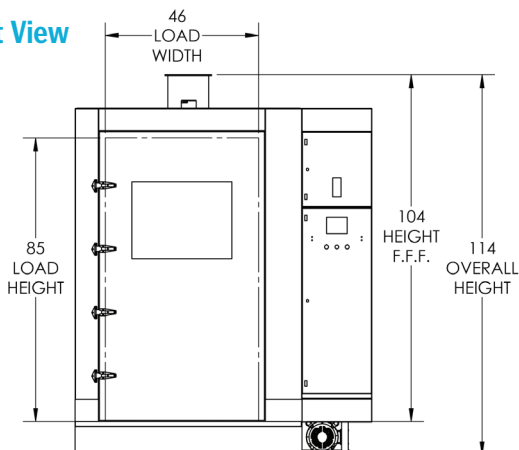

Side View

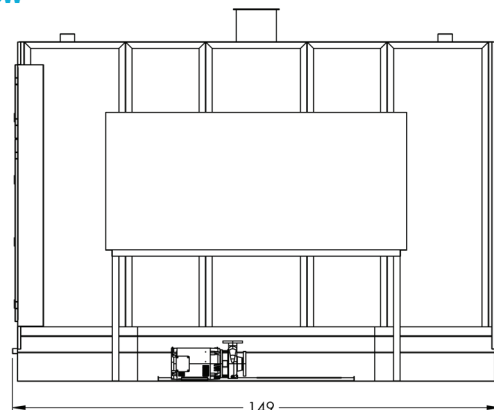

420LX Cage and Rack Washer Sell Sheet_M1025_1.00 2021-0318



LYNX

Cage & Rack Washers

Model 420RS

Ensuring efficient cleaning for all your animal care items

The LYNX Model 420RS (formerly Scientek SW6700) Cage and Rack Washers are heavy duty, large capacity reliable hydro-spray washers designed for ease of use, minimal maintenance, and highest cleanability of caging, bottles, racks, debris pans, and other items used in the care of laboratory animals. These washers deliver high performance within a simplistic design. The system is provided with greater flexibility to meet today's "green" initiatives and high throughput demands. LYNX standardizes on non-proprietary parts on all equipment. Pit mounting is standard.

Standard Features

- Heavy-duty Hinge Door
- Modular Construction
- Knock-down Shipment
- **Rotating** Spray Delivery System
- Personnel Safety Features
- PLC Control System with Full Color HMI Touch Screen
- 10 Configurable Cycles
- Automatic Self-cleaning Screen
- Temperature Guarantee
- Insulated Construction
- Incoming Utility Gauges
- Interior Illumination
- SS Recirculation Piping and Components
- Non-proprietary Parts

Construction

LYNX 420RS Cage and Rack Washers are provided with a heavy-duty stainless steel door with port view glass window. Recirculated water is heated by a stainless steel steam coil to achieve guaranteed treatment temperatures. A color touch screen control panel provides a user-friendly interface for selecting, programming, and monitoring cycles. Unit is provided with a stainless steel 15 HP treatment pump with a direct read pump pressure gauge.

Optional Features

- **Shallow Base Unit** (6")
- Pit or Floor Mounted
- Pass-thru Unit
- Right or Left Hand Services
- Re-usable Throwaway Alkaline Tank
- House Hot Water Heat Exchanger
- Integral Data Collection System
- Drain Discharge Cooling
- Automatic Damper
- SS Exhaust Fan
- Low Steam Pressure Package
- Pass-thru Door Interlock System
- Air Compressor
- Printer
- Seismic Tie Down
- Detergent Dispensing Systems
- pH Neutralization System
- Feeder Bottle Washing System
- Automatic Water Rack Flush System
- Split Base for Special Entry
- Utility Enclosure Panels
- Inclined Floor Grating
- Barrier Wall Flange(s)

Accessories

- Floor Ramps
- Bottle Wash Cart
- Universal Cage Wash Cart
- High Capacity Cage Wash System

Utilities

Electrical (E)	3-60-208/480/600V, 20HP
Hot Water (HW)	1" NPT, 35 PSI, 25 GPM @ 140° F ± 5° F (95 gallon sump capacity)
Cold Water (CW)*	1" NPT, 35 PSI, 25 GPM @ 50° F ± 5° F
Steam (S)	1½" NPT, 40-60 PSI, Dynamic ± 5 PSI, 450-600 #/Hr Flow Rate
Condensate (C)	1" NPT + ¾" NPT
Air (A)	¼" NPT, 80-100 PSI, 1-2 CFM Flow Rate
Drain (D)	12" x 12" Floor Sink with 4" Floor Drain (<i>minimum</i>), 530 GPM Flow Rate
Vent (V)	8" x 22" Duct, Saturated Vapor @ 190° F, 1 DC (1200 CFM) + 1 IDC (500 CFM)

*CW - Required if drain discharge cool-down package ordered

Model	Standard Chamber Size W x H x D	Standard Unit Size W x H x D	Opt. Door Widths	Opt. Door Heights	Opt. Chamber Lengths
420RS ¹	48" x 88" x 128"	62.75" x 95" x 132"	36", 42", 46"	74", 82"	120"

Washers can be designed to any size to meet your application requirements. Certain options can increase unit sizes.

1) 420RS (formerly Scientek SW6700)

Representative Drawing

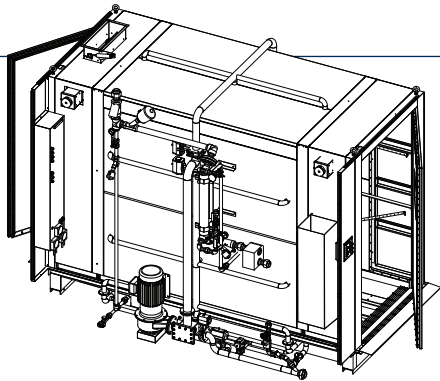

Top View

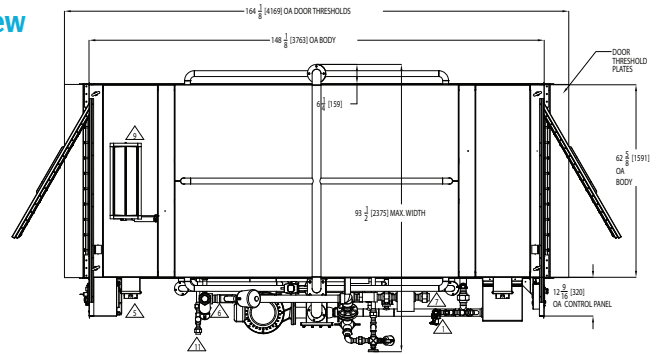

Front View

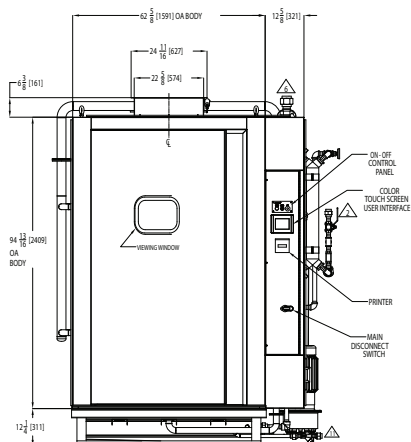

Side View

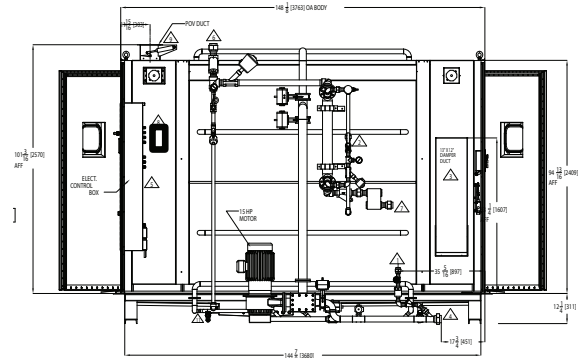

420RS Cage and Rack Washer Sell Sheet_M1041_1.00 2021-0318

LYNX

Cage & Rack Washers

Model 430LX



Ensuring efficient cleaning for all your animal care items

The LYNX Model 430LX Cage and Rack Washers are heavy duty, large capacity reliable hydro-spray washers designed for ease of use, minimal maintenance, and highest cleanability of caging, bottles, racks, debris pans, and other items used in the care of laboratory animals. These washers deliver high performance within a simplistic design. The system is provided with greater flexibility to meet today's "green" initiatives and high throughput demands. LYNX standardizes on non-proprietary parts on all equipment. Pit mounting is standard.

Standard Features

- Heavy-duty Hinge Door
- Modular Construction
- Knock-down Shipment
- **Oscillating** Spray Delivery System
- Personnel Safety Features
- PLC Control System with Full Color HMI Touch Screen
- 12 Configurable Cycles
- Neutralization System
- Automatic Self-cleaning Screen
- Temperature Guarantee
- Insulated Construction
- Incoming Utility Gauges
- Interior Illumination
- SS Recirculation Piping and Components
- Non-proprietary Parts

Construction

LYNX 430LX Cage and Rack Washers are provided with a heavy-duty stainless steel door with double pane glass window. Recirculated water is heated by a stainless steel steam coil to achieve guaranteed treatment temperatures. A color touch screen control panel provides a user-friendly interface for selecting, programming, and monitoring cycles. Unit is provided with two (2) stainless steel 10 HP treatment pumps with direct read pump pressure gauges.

Optional Features

- Pit or Floor Mounted
- Pass-thru Unit
- Right or Left Hand Services
- LYNX OPTI-Wash™ Water Saving System
- Re-usable Throwaway Alkaline and/or Acid Tank
- Heated Rinse Tank
- House Hot Water Heat Exchanger
- Electric Heat System
- Integral Data Collection System
- LYNX Smart-Cool™ System
- Drain Discharge Cooling - Injected/Tank
- Automatic Damper
- SS Exhaust Fan
- Low Steam Pressure Package
- Pass-thru Door Interlock System
- Air Compressor
- Printer
- Seismic Tie Down
- Detergent Dispensing Systems
- pH Neutralization System
- Feeder Bottle Washing System

Optional Features *cont*

- Integrated Pan Wash System
- Automatic Water Rack Flush System
- Split Base for Special Entry
- Port-view Door Window
- 1/3 View Glass Door
- Full View Glass Door
- 36"-54" Door Widths Available (46" wide standard)
- Active Door Seal
- Utility Enclosure Panels
- Inclined Floor Grating
- Automatic Inclined Floor Grating
- Steam Heated Dryer System
- Barrier Wall Flange(s)

Accessories

- Floor Ramps
- Modular Walls
- Bottle Wash Cart
- Universal Cage Wash Cart

Utilities

Electrical (E)	3-60-208/480V, 24HP
Hot Water (HW)	1½" NPT, 35 PSI, 50 GPM @ 140° F ± 5° F (40 gallon sump capacity)
Cold Water (CW)*	1½" NPT, 35 PSI, 100 GPM @ 50° F ± 5° F
Steam (S)	2" NPT, 45-80 PSI, Dynamic ± 5 PSI, 1000-1200 #/Hr Flow Rate
Condensate (C)	2" NPT
Air (A)	½" NPT, 80-100 PSI, 4-6 CFM Flow Rate
Drain (D)	(2) 12" x 12" Floor Sink with (2) 4" Floor Drain (<i>minimum</i>), 180 GPM Flow Rate
Vent (V)	12" ID Duct, 750 CFM, Saturated Vapor @ 190° F

*CW - Required if drain discharge cool-down package ordered

Model	Standard Chamber Size W x H x D	Standard Unit Size W x H x D	Opt. Door Widths	Opt. Door Heights	Opt. Chamber Lengths
430LX	46" x 85" x 188"	89" x 104" x 196"	36", 48", 54"	88", 93", 96"	152", 164", 170", 176", 188"+

Washers can be designed to any size to meet your application requirements.

Representative Drawings

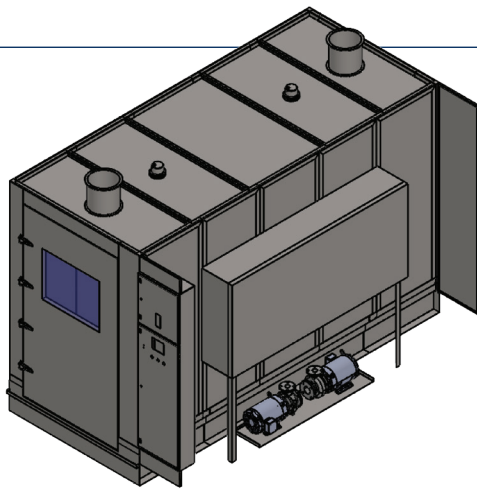

Front View

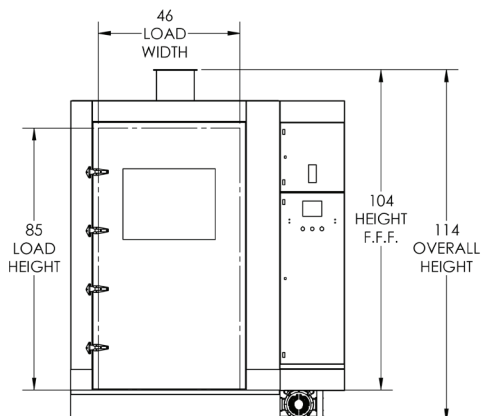

Top View

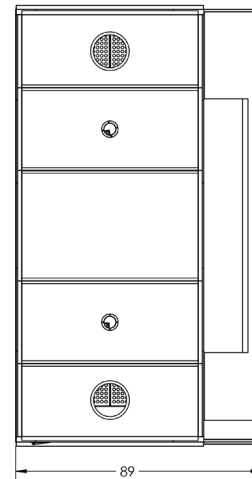

Side View

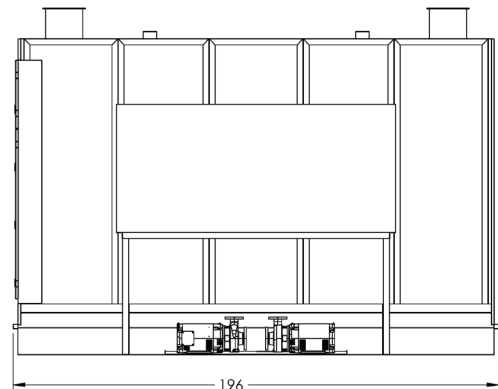

430LX Cage and Rack Washer Sell Sheet_M1026_1.00 2021-0318



LYNX

Cage & Rack Washers

Model 430RS

Ensuring efficient cleaning for all your animal care items

The LYNX Model 430RS (formerly Scientek SW6900) Cage and Rack Washers are heavy duty, large capacity reliable hydro-spray washers designed for ease of use, minimal maintenance, and highest cleanability of caging, bottles, racks, debris pans, and other items used in the care of laboratory animals. These washers deliver high performance within a simplistic design. The system is provided with greater flexibility to meet today's "green" initiatives and high throughput demands. LYNX standardizes on non-proprietary parts on all equipment. Pit mounting is standard.

Standard Features

- Heavy-duty Hinge Door
- Modular Construction
- Knock-down Shipment
- **Rotating** Spray Delivery System
- Personnel Safety Features
- PLC Control System with Full Color HMI Touch Screen
- 10 Configurable Cycles
- Automatic Self-cleaning Screen
- Temperature Guarantee
- Insulated Construction
- Incoming Utility Gauges
- Interior Illumination
- SS Recirculation Piping and Components
- Non-proprietary Parts

Construction

LYNX 430RS Cage and Rack Washers are provided with a heavy-duty stainless steel door with port view glass window. Recirculated water is heated by a stainless steel steam coil to achieve guaranteed treatment temperatures. A color touch screen control panel provides a user-friendly interface for selecting, programming, and monitoring cycles. Unit is provided with a stainless steel 20 HP treatment pump with a direct read pump pressure gauge.

Optional Features

- **Shallow Base Unit** (6")
- Pit or Floor Mounted
- Pass-thru Unit
- Right or Left Hand Services
- Re-usable Throwaway Alkaline Tank
- House Hot Water Heat Exchanger
- Integral Data Collection System
- Drain Discharge Cooling
- Automatic Damper
- SS Exhaust Fan
- Low Steam Pressure Package
- Pass-thru Door Interlock System
- Air Compressor
- Printer
- Seismic Tie Down
- Detergent Dispensing Systems
- pH Neutralization System
- Feeder Bottle Washing System
- Automatic Water Rack Flush System
- Split Base for Special Entry
- Utility Enclosure Panels
- Inclined Floor Grating
- Barrier Wall Flange(s)

Accessories

- Floor Ramps
- Bottle Wash Cart
- Universal Cage Wash Cart
- High Capacity Cage Wash System

Utilities

Electrical (E)	3-60-208/480/600V, 23HP
Hot Water (HW)	1" NPT, 35 PSI, 25 GPM @ 140° F ± 5° F (95 gallon sump capacity)
Cold Water (CW)*	1" NPT, 35 PSI, 25 GPM @ 50° F ± 5° F
Steam (S)	2" NPT, 40-60 PSI, Dynamic ± 5 PSI, 900 #/Hr Flow Rate
Condensate (C)	1" NPT + ¾" NPT
Air (A)	¼" NPT, 80-100 PSI, 1-2 CFM Flow Rate
Drain (D)	12" x 12" Floor Sink with 4" Floor Drain (<i>minimum</i>), 550 GPM Flow Rate
Vent (V)	8" x 22" Duct, Saturated Vapor @ 190° F, 1 DC (1200 CFM) + 1 IDC (500 CFM)

*CW - Required if drain discharge cool-down package ordered

Model	Standard Chamber Size W x H x D	Standard Unit Size W x H x D	Opt. Door Widths	Opt. Door Heights	Opt. Chamber Lengths
430RS ¹	48" x 88" x 188"	62.75" x 95" x 192"	42", 46"	74", 82"	154", 164", 170"

Washers can be designed to any size to meet your application requirements. Certain options can increase unit sizes.

1) 430RS (formerly Scientek SW6900)

Representative Drawing

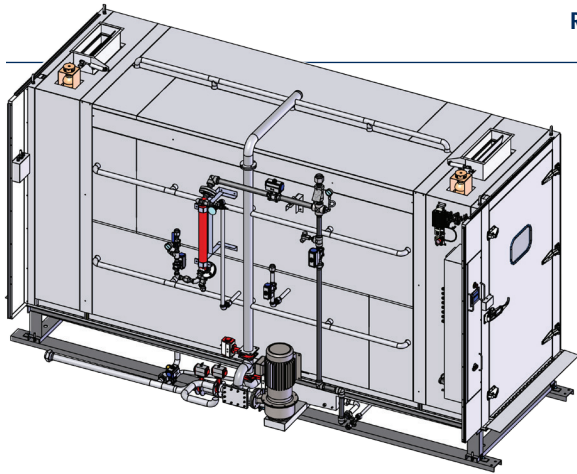

Top View

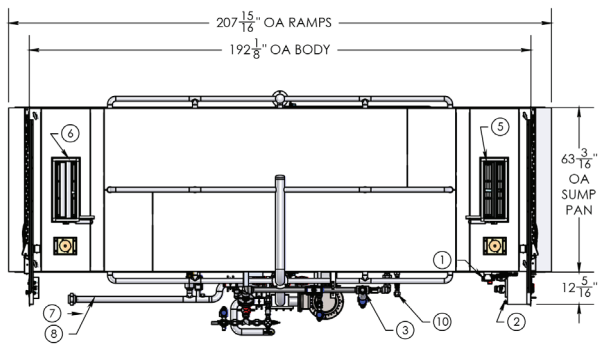

Front View

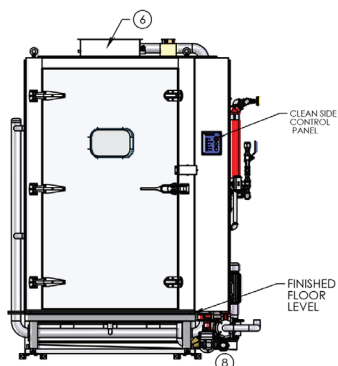

Side View

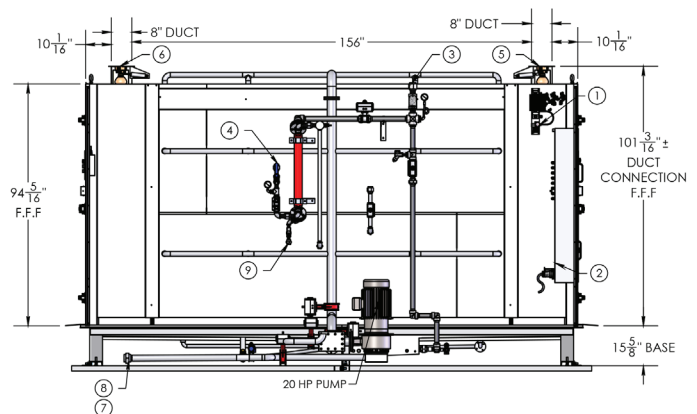

430RS Cage and Rack Washer Sell Sheet_M1042_1.00 2021-0318



LYNX

Cage & Rack Washers

Model 450LX

Ensuring efficient cleaning for all your animal care items

The LYNX Model 450LX Cage and Rack Washers are heavy duty, large capacity reliable hydro-spray washers designed for ease of use, minimal maintenance, and highest cleanability of caging, bottles, racks, debris pans, and other items used in the care of laboratory animals. These washers deliver high performance within a simplistic design. The system is provided with greater flexibility to meet today's "green" initiatives and high throughput demands. LYNX standardizes on non-proprietary parts on all equipment. Pit mounting is standard.

Standard Features

- Heavy-duty Hinge Doors
- Modular Construction
- Knock-down Shipment
- **Oscillating** Spray Delivery System
- Personnel Safety Features
- PLC Control System with Full Color HMI Touch Screen
- 12 Configurable Cycles
- Neutralization System
- Automatic Self-cleaning Screen
- Temperature Guarantee
- Insulated Construction
- Incoming Utility Gauges
- Interior Illumination
- SS Recirculation Piping and Components
- Non-proprietary Parts

Construction

LYNX 450LX Cage and Rack Washers are provided with a heavy-duty stainless steel doors with double pane glass window. Recirculated water is heated by a stainless steel steam coil to achieve guaranteed treatment temperatures. A color touch screen control panel provides a user-friendly interface for selecting, programming, and monitoring cycles. Unit is provided with two (2) stainless steel 10-15 HP treatment pumps with direct read pump pressure gauges.

Optional Features

- Pit or Floor Mounted
- Pass-thru Unit
- Right or Left Hand Services
- LYNX OPTI-Wash™ Water Saving System
- Re-usable Throwaway Alkaline and/or Acid Tank
- Heated Rinse Tank
- House Hot Water Heat Exchanger
- Electric Heat System
- Integral Data Collection System
- LYNX Smart-Cool™ System
- Drain Discharge Cooling - Injected/Tank
- Automatic Damper
- SS Exhaust Fan
- Low Steam Pressure Package
- Pass-thru Door Interlock System
- Air Compressor
- Printer
- Seismic Tie Down
- Detergent Dispensing Systems
- pH Neutralization System
- Feeder Bottle Washing System

Optional Features *cont*

- Integrated Pan Wash System
- Automatic Water Rack Flush System
- Split Base for Special Entry
- Port-view Door Window
- 1/3 View Glass Door
- Full View Glass Door
- 36"-54" Door Widths Available (46" wide standard)
- Active Door Seal
- Utility Enclosure Panels
- Inclined Floor Grating
- Automatic Inclined Floor Grating
- Steam Heated Dryer System
- Barrier Wall Flange(s)

Accessories

- Floor Ramps
- Modular Walls
- Bottle Wash Cart
- Universal Cage Wash Cart

Utilities

Electrical (E)	3-60-208/480V, 22-32HP
Hot Water (HW)	1½" NPT, 35 PSI, 50 GPM @ 140° F ± 5° F (40 gallon sump capacity)
Cold Water (CW)*	1½" NPT, 35 PSI, 100 GPM @ 50° F ± 5° F
Steam (S)	2" NPT, 45-80 PSI, Dynamic ± 5 PSI, 1000-1200 #/Hr Flow Rate
Condensate (C)	2" NPT
Air (A)	½" NPT, 80-100 PSI, 4-6 CFM Flow Rate
Drain (D)	(2) 12" x 12" Floor Sink with (2) 4" Floor Drain (<i>minimum</i>), 180 GPM Flow Rate
Vent (V)	12" ID Duct, 750 CFM, Saturated Vapor @ 190° F

*CW - Required if drain discharge cool-down package ordered

Model	Standard Chamber Size W x H x D	Standard Unit Size W x H x D	Opt. Door Widths	Opt. Door Heights	Opt. Chamber Lengths
450LX	72" x 85" x 141"	122" x 104" x 149"-226"	60", 84"	88", 93", 96"	All 85"- 188"+

Washers can be designed to any size to meet your application requirements.

Representative Drawings

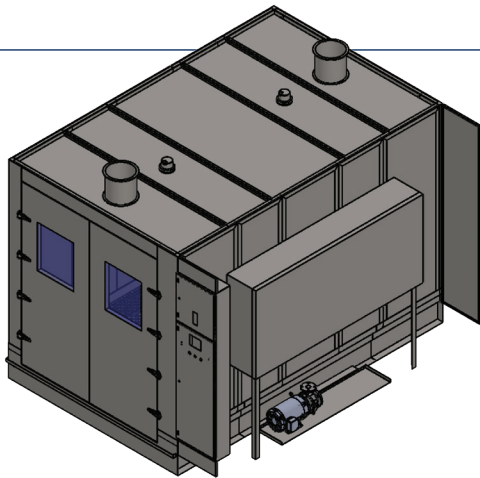

Top View

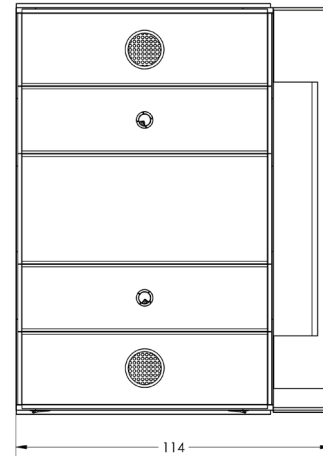

Front View

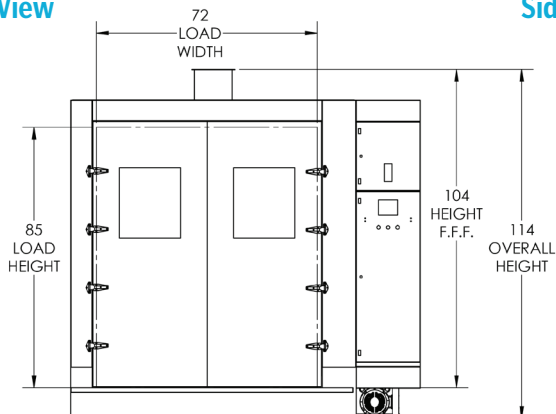

Side View

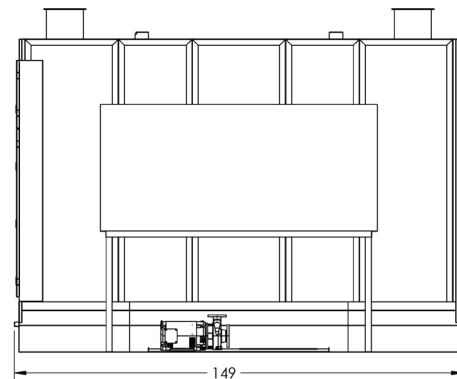

450LX Cage and Rack Washer Sell Sheet_M1027_1.00 2021-0318

LYNX

Cage & Rack Washers

Model 450RS



Ensuring efficient cleaning for all your animal care items

The LYNX Model 450RS (formerly Scientek SW6700W) Cage and Rack Washers are heavy duty, large capacity reliable hydro-spray washers designed for ease of use, minimal maintenance, and highest cleanability of caging, bottles, racks, debris pans, and other items used in the care of laboratory animals. These washers deliver high performance within a simplistic design. The system is provided with greater flexibility to meet today's "green" initiatives and high throughput demands. LYNX standardizes on non-proprietary parts on all equipment. Pit mounting is standard.

Standard Features

- Heavy-duty Hinge Door
- Modular Construction
- Knock-down Shipment
- **Rotating** Spray Delivery System
- Personnel Safety Features
- PLC Control System with Full Color HMI Touch Screen
- 10 Configurable Cycles
- Automatic Self-cleaning Screen
- Temperature Guarantee
- Insulated Construction
- Incoming Utility Gauges
- Interior Illumination
- SS Recirculation Piping and Components
- Non-proprietary Parts

Construction

LYNX 450RS Cage and Rack Washers are provided with heavy-duty stainless steel doors with port view glass windows. Recirculated water is heated by a stainless steel steam coil to achieve guaranteed treatment temperatures. A color touch screen control panel provides a user-friendly interface for selecting, programming, and monitoring cycles. Unit is provided with a stainless steel 20 HP treatment pump with a direct read pump pressure gauge.

Optional Features

- **Shallow Base Unit** (6")
- Pit or Floor Mounted
- Pass-thru Unit
- Right or Left Hand Services
- Re-usable Throwaway Alkaline Tank
- House Hot Water Heat Exchanger
- Integral Data Collection System
- Drain Discharge Cooling
- Automatic Damper
- SS Exhaust Fan
- Low Steam Pressure Package
- Pass-thru Door Interlock System
- Air Compressor
- Printer
- Seismic Tie Down
- Detergent Dispensing Systems
- pH Neutralization System
- Feeder Bottle Washing System
- Automatic Water Rack Flush System
- Split Base for Special Entry
- Utility Enclosure Panels
- Inclined Floor Grating
- Barrier Wall Flange(s)

Accessories

- Floor Ramps
- Bottle Wash Cart
- Universal Cage Wash Cart
- High Capacity Cage Wash System

Utilities

Electrical (E)	3-60-208/480/600V, 23HP
Hot Water (HW)	1" NPT, 35 PSI, 25 GPM @ 140° F ± 5° F (125 gallon sump capacity)
Cold Water (CW)*	1" NPT, 35 PSI, 25 GPM @ 50° F ± 5° F
Steam (S)	1½" NPT, 40-60 PSI, Dynamic ± 5 PSI, 1000 #/Hr Flow Rate
Condensate (C)	1" NPT + ¾" NPT
Air (A)	¼" NPT, 80-100 PSI, 1-2 CFM Flow Rate
Drain (D)	12" x 12" Floor Sink with 4" Floor Drain (<i>minimum</i>), 530 GPM Flow Rate
Vent (V)	8" x 22" Duct, Saturated Vapor @ 190° F, 1 DC (1200 CFM) + 1 IDC (500 CFM)

*CW - Required if drain discharge cool-down package ordered

Model	Standard Chamber Size W x H x D	Standard Unit Size W x H x D	Opt. Door Widths	Opt. Door Heights	Opt. Chamber Lengths
450RS ¹	68" x 88" x 128"	83.25" x 95" x 132"	62", 74", 84"	90", 93", 96"	109", 140", 150", 160", 165"

Washers can be designed to any size to meet your application requirements. Certain options can increase unit sizes.

1) 450RS (formerly Scientek SW6700W)

Representative Drawing

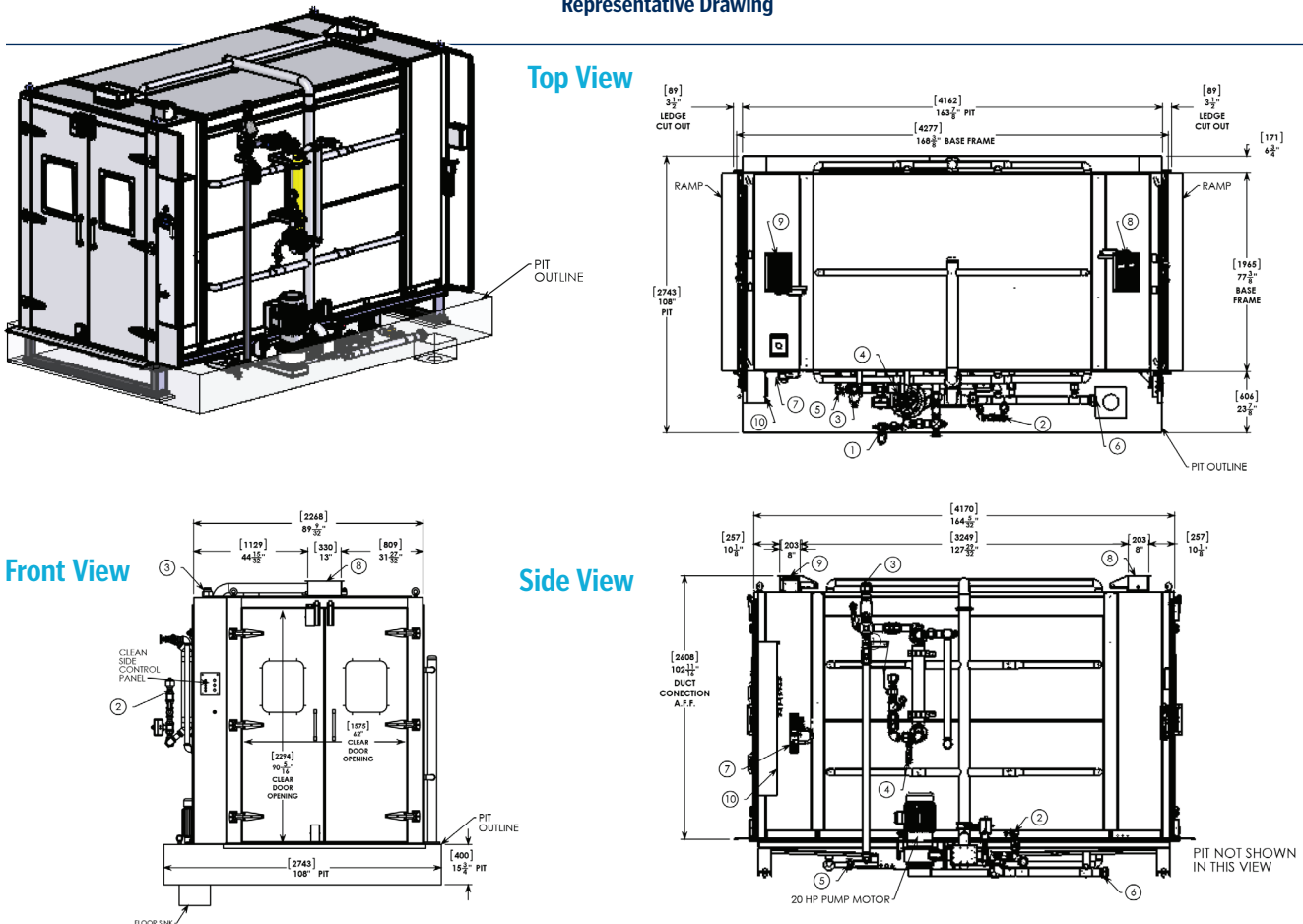

450RS Cage and Rack Washer Sell Sheet_M1043_1.00 2021-0318

LYNX

Cage & Rack Washers

Model 455LX



Ensuring efficient cleaning for all your animal care items

The LYNX Model 455LX (dual chamber) Cage and Rack Washers are heavy duty, large capacity reliable hydro-spray washers designed for ease of use, minimal maintenance, and highest cleanability of caging, bottles, racks, debris pans, and other items used in the care of laboratory animals. These washers deliver high performance and twice the capacity maintaining a simplistic design. The system is provided with greater flexibility to meet today's "green" initiatives and high throughput demands. LYNX standardizes on non-proprietary parts on all equipment. Pit mounting is standard.

Standard Features

- Dual Load Chambers
- Heavy-duty Hinge Doors
- Modular Construction
- Knock-down Shipment
- **Oscillating** Spray Delivery System
- Personnel Safety Features
- PLC Control System with Full Color HMI Touch Screen
- 12 Configurable Cycles
- Neutralization System
- Automatic Self-cleaning Screen
- Temperature Guarantee
- Insulated Construction
- Incoming Utility Gauges
- Interior Illumination
- SS Recirculation Piping and Components
- Non-proprietary Parts

Construction

LYNX 455LX Cage and Rack Washers are provided with heavy-duty stainless steel doors with double pane glass windows. Recirculated water is heated by a stainless steel steam coil to achieve guaranteed treatment temperatures. A color touch screen control panel provides a user-friendly interface for selecting, programming, and monitoring cycles. Unit is provided with two (2) stainless steel 10-15 HP treatment pumps with direct read pump pressure gauges.

Optional Features

- Pit or Floor Mounted
- Pass-thru Unit
- Right or Left Hand Services
- LYNX OPTI-Wash™ Water Saving System
- Re-usable Throwaway Alkaline and/or Acid Tank
- Heated Rinse Tank
- House Hot Water Heat Exchanger
- Electric Heat System
- Integral Data Collection System
- LYNX Smart-Cool™ System
- Drain Discharge Cooling - Injected/Tank
- Automatic Damper
- SS Exhaust Fan
- Low Steam Pressure Package
- Pass-thru Door Interlock System
- Air Compressor
- Printer
- Seismic Tie Down
- Detergent Dispensing Systems
- pH Neutralization System
- Feeder Bottle Washing System

Optional Features *cont*

- Integrated Pan Wash System
- Automatic Water Rack Flush System
- Split Base for Special Entry
- Port-view Door Window
- 1/3 View Glass Door
- Full View Glass Door
- 36"-54" Door Widths Available (46" wide standard)
- Active Door Seal
- Utility Enclosure Panels
- Inclined Floor Grating
- Automatic Inclined Floor Grating
- Steam Heated Dryer System
- Barrier Wall Flange(s)

Accessories

- Floor Ramps
- Modular Walls
- Bottle Wash Cart
- Universal Cage Wash Cart

Utilities

Electrical (E)	3-60-208/480V, 22-32HP
Hot Water (HW)	1½" NPT, 35 PSI, 50 GPM @ 140° F ± 5° F (40 gallon sump capacity)
Cold Water (CW)*	1½" NPT, 35 PSI, 100 GPM @ 50° F ± 5° F
Steam (S)	2" NPT, 45-80 PSI, Dynamic ± 5 PSI, 1000-1200 #/Hr Flow Rate
Condensate (C)	2" NPT
Air (A)	½" NPT, 80-100 PSI, 4-6 CFM Flow Rate
Drain (D)	(2) 12" x 12" Floor Sink with (2) 4" Floor Drain (<i>minimum</i>), 180 GPM Flow Rate
Vent (V)	12" ID Duct, 750 CFM, Saturated Vapor @ 190° F

*CW - Required if drain discharge cool-down package ordered

Model	Standard Chamber Size W x H x D	Standard Unit Size W x H x D	Opt. Door Widths	Opt. Door Heights	Opt. Chamber Lengths
455LX	Dual 46" x 85" x 141"	147" x 104" x 93"-196"	36", 48", 54"	88", 93", 96"	All 85"- 188"+

Washers can be designed to any size to meet your application requirements.

Representative Drawings

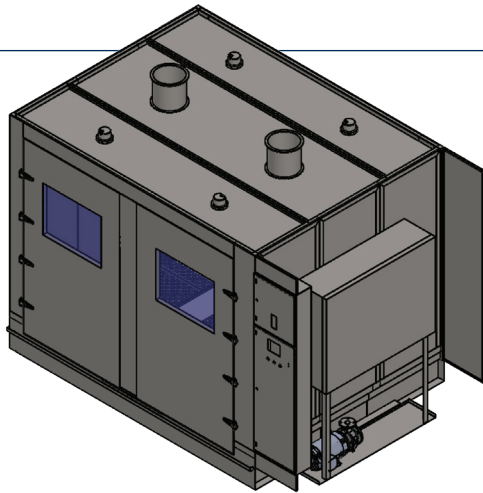

Top View

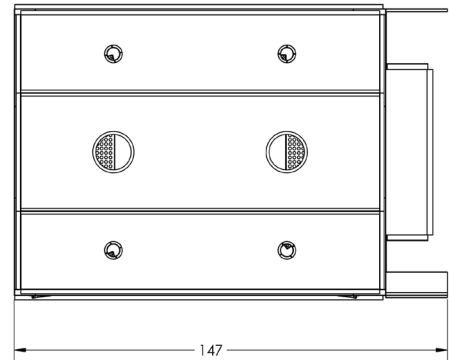

Front View

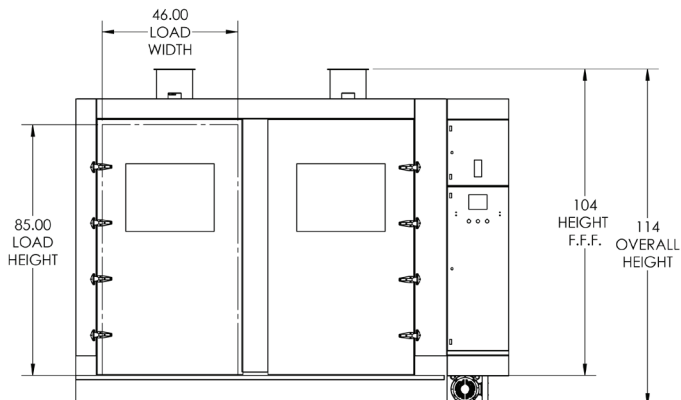

Side View

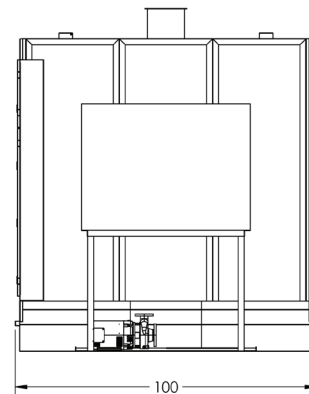

455LX Cage and Rack Washer Sell Sheet_M1039_1.00 2021-0318