



STAINLESS STEEL FREEZERS

Designed to meet the demanding requirements of scientific and laboratory applications.

Standard Features

- 300 Series Stainless Steel Interior And Exterior
- -20° C Operating Temperature
- Large Digital Display For Quick and Easy Temperature Identification
- Recessed Door Handles (Lifetime Guarantee)
- Door Locks
- Magnetic Door Gaskets
- Adjustable Vinyl Coated Wire Shelves (3 Per Door Section)
- Incandescent Interior Lighting
- 4" Diameter Swivel Castors (Field Installed)
Locking Castors Provided For Front Set.
- Corrosion Resistant Epoxy Coated Evaporator
- Oversized And Balanced, Environmentally Friendly (134A) Refrigeration System
- Warranty: 1 Year Parts and Labor;
5 Year Compressor Parts

Optional Features

- 6" Legs
- Additional shelves
- Chart Recorders



TS-49F



TS-23F

REPRESENTED BY:

BCA SCIENTIFIC INC.
3395 Brett Road, Mississauga, ON, L5L 4N7
Phone: 905-820-6125 Fax: 905-820-8958
www.BCAscientific.com

Front View

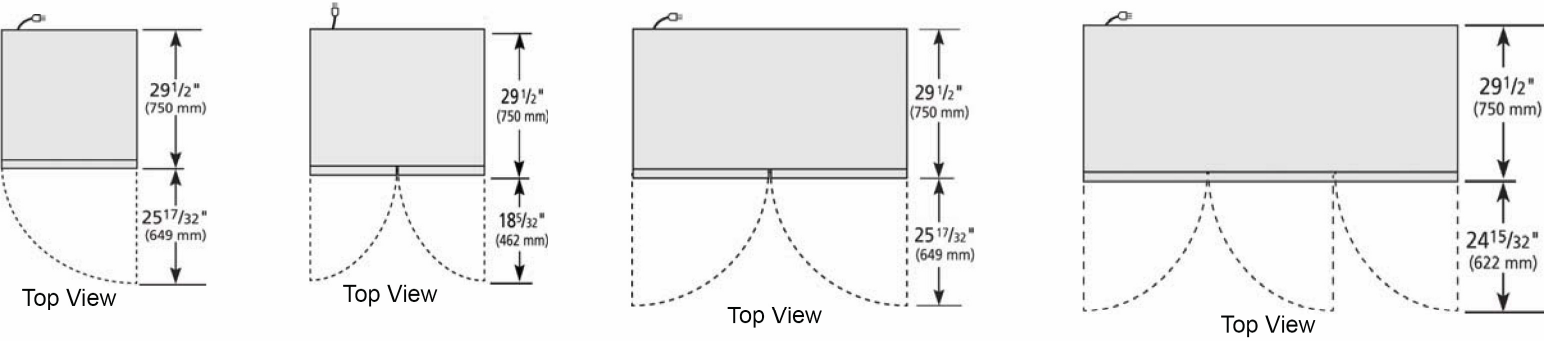
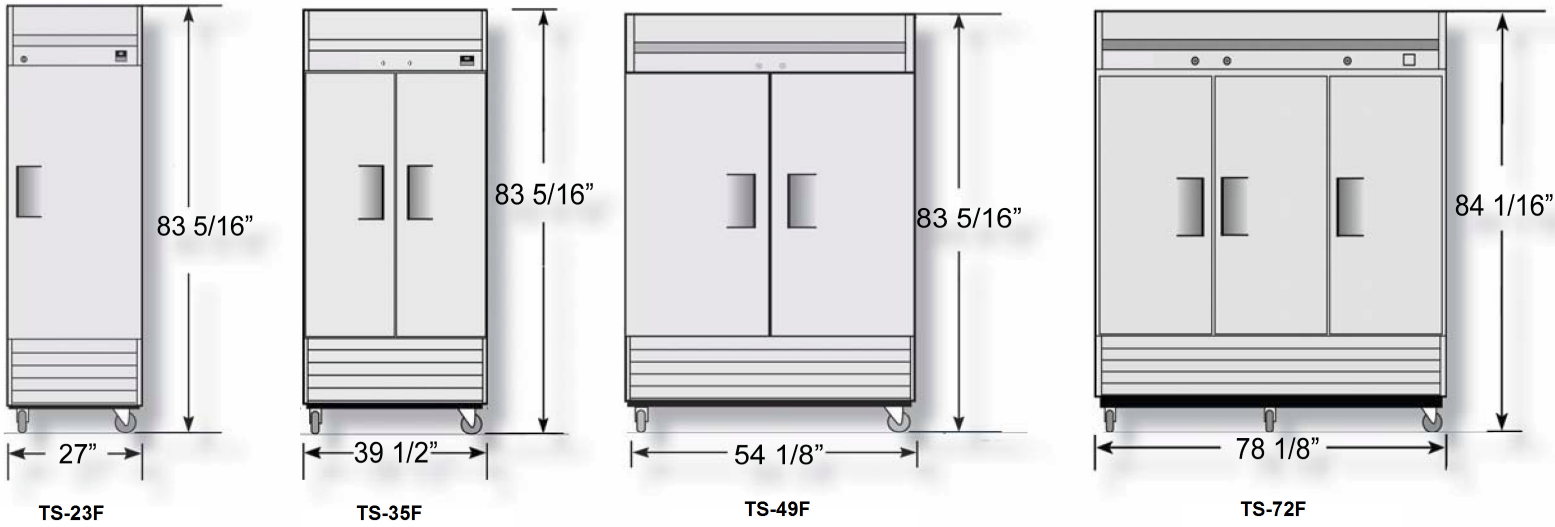

Hinged Solid Door

Model #	Cu. Ft. Interior	Number of Shelves	Number of Doors	Exterior Dimensions			Crated Weight (lbs.)
				L"	D"	H"	
TS-23F	23	3	1	27	29 1/2	83 5/16	315
TS-35F	35	6	2	39 1/2	29 1/2	83 5/16	480
TS-49F	49	6	2	54 1/8	29 1/2	83 5/16	510
**TS-72F	72	9	3	78 1/8	29 1/2	84 1/16	710

All Units-Height includes 5" Casters- Shipped Separately
 **Requires 208-230/60 Hz, single phase, 3 pole, 4 wire circuit.

REPRESENTED BY:

BCA SCIENTIFIC INC.
 3395 Brett Road, Mississauga, ON, L5L 4N7
 Phone: 905-820-6125 Fax: 905-820-8958
www.BCAscientific.com

